



saiaburgess

Smart solutions for comfort and safety

applications & functions by product groups

linear solenoids

- open frames
- soft shifts
- low profiles
- tubulars

rotary solenoids

- rotary
- BTA
- Ultimag



saia-burgess

Smart solutions for comfort and safety

open frames

applications & functions



- **application: circuit breaker**
- **market segment: industrial equipment**





success factors:

Quick (ms range) and strong (180N) movement from open frame solenoid necessary

technical circuit breaker knowledge in order to develop the right product

SB and customer development process in parallel

- 
- **function: switching to different power supply by moving a rack mechanism**
 - **product: B77M-3000**
- 



Smart solutions for comfort and safety

- **application: minimum voltage relay**
- **market segment: circuit breaker**

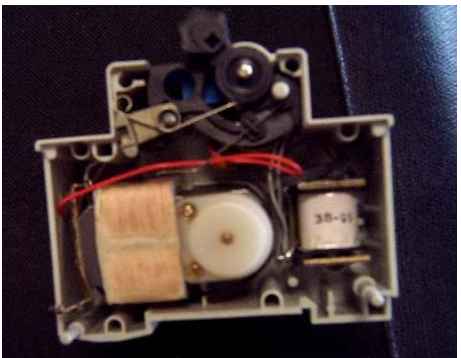

success factors:

- good knowledge of system
 - little dimensions
 - no residual magnetism
-



- **function: release with undervoltage (80%)**
- **product: B17**





Smart solutions for comfort and safety

- **application: sterilising medical tools**
- **market segment: medical**



success factors:

right standard size +
performance

short + quick movement
required



- **function: locking mechanism**
- **product: C34**





Smart solutions for comfort and safety

- **application: textile machine, spinning box**
- **market segment: industrial equipment**
- **customer: textile machine manufacturer**

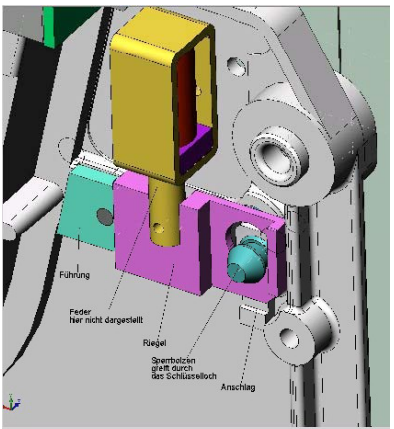

success factors:

fulfilling special high security customer technical needs

powerless holding force due to permanent magnet

low cost production in Asia

- **function: keep the door closed for security reason during cutting process**
- **product: customised latching open frame**





Smart solutions for comfort and safety

- **application: clothes dispenser**
- **market segment: vending**



success factors:
simple locking device with
special plunger + return spring
standard size suitable for
modifying solution



- **function: locking of clothes distributing compartment**
- **product: B75M-3001**





Smart solutions for comfort and safety

- **application: 50k A circuit breaker**
- **market segment: industrial equipment**

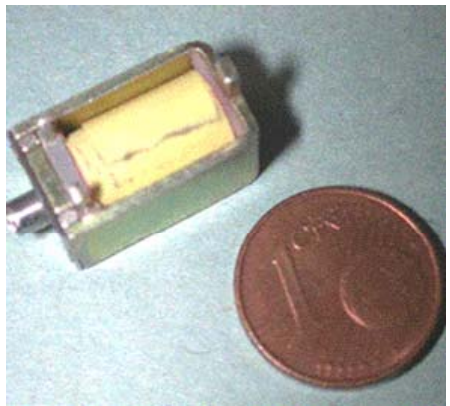

success factors:
small size
high holding force + low release current
high shock resistance

- **function: indication of phase with short circuit**
- **product: customised maglatch open frame**





Smart solutions for comfort and safety

- application: gaming machine
- market segment: gaming



success factors:

special plunger design for required force stroke line
design for long life (1 mil) cycle requirement in application
high force with short duty cycle



- function: lever moving in coin ejection unit for coin drop out
- product: B76M-3000





Smart solutions for comfort and safety

- application: coffee vending machine
- market segment: vending



success factors:

no vibration with AC unit
successful SB testing in application
production in Poland

- function: actuate coffee powder dosing flap
- product: B75M





Smart solutions for comfort and safety

- application: door system + cash distributor locking system
- market segment: industrial equipment



success factors:
standard product modification

- function: locking mechanisme
- product: B75M





Smart solutions for comfort and safety

- **application: cash drawers**
- **market segment: commercial equipment**

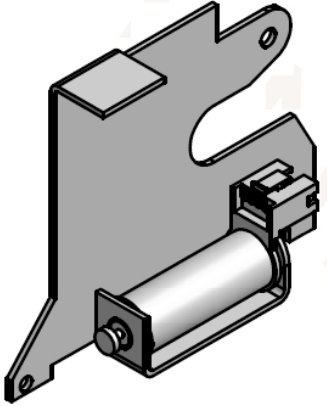

success factors:

short movement with little stroke to release a latch mechanism
offering subassembly
production in Asia

- **function: releasing of cash drawer compartment**
- **product: open frame subassembly**





Smart solutions for comfort and safety

- **application: espresso coffee machine**
- **market segment: vending**

success factors:

Quick modification of standard product

Short movement with little stroke to release locking mechanism

SB delivers all actuators for the application (3 motors + 1 solenoid + 13 switches)



- **function: locking of milk compartment**
- **product: C5**





Success Factor: wide product range

➤ example: coffee machine (Saeco)

c-open frame solenoid
function: compartment locking



Rotary 20mm step motor
function: spume maker



Rotary 28mm step motor with gearbox
function: cleaning valve



13 micro switches
functions: various

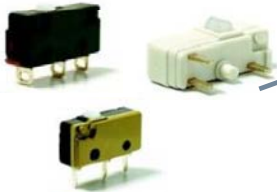

linear 28mm step motor (72mm stroke)
function: cup lifter





Smart solutions for comfort and safety

- **application: safety positioning switch**
- **market segment: circuit breakers**

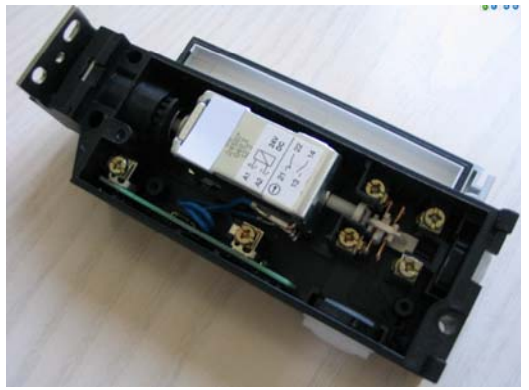

success factors:

B76 available for modification of Harting standard solenoid as replacement

quick movement required

- **function: open/close power circuit and close of door latch**
- **product: B76M**





Smart solutions for comfort and safety

- **application: release mechanism for oxygene mask in air planes**
- **market segment: aviation**

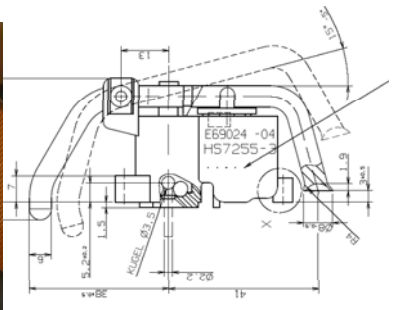

- **function: latch mechanism with attached oxygen mask by permanent magnet, release by solenoid coil**
- **product: special bistable subassembly**

success factors:

know-how on bistable solutions in order to co-develop with customer

Ability to offer such subassemblies





- application: alcohol tester
- market segment: medical

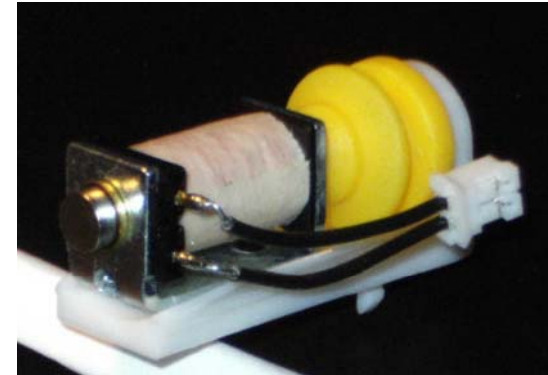

success factors:

standard product fits

Delivery of subassembly with
push version + connector +
bellows + white base



- function: pushing of bulk to get out air sample
- product: C5 subassembly



Smart solutions for comfort and safety

- **application: parking management**
- **market segment: commercial equipment**



success factors:

supply subassembly with lead wire +connectors + sleeve
one instead of two suppliers

- **function: driving of mechanical locking system**
- **product: B14 subassembly**





Open frame solenoids:

main characteristics:

quick moving (ms range)

high forces (up to several hundred Newtons)

short linear stroke (max 20-30mm)

Special features:

DC and AC power supply possible

most economical solution amongst solenoids



B75



B76



B77

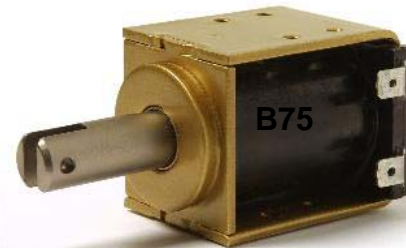

B4HD



C8



C26



B41



B11



saiaburgess

Smart solutions for comfort and safety

Soft shifts applications & functions



Smart solutions for comfort and safety

- **application: eye test equipment**
- **market segment: medical**

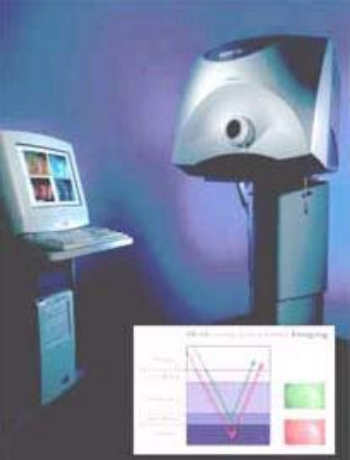

success factors:

- Linear force stroke line with special SB design
 - Closed loop function to vary stroke
 - Modification of a standard design
-



- **function: air valve drive for pupile regulation**
- **product: soft shift**





Soft shift solenoids:

main characteristics:

quick moving (ms range)

high forces (up to several hundred Newtons)

short linear stroke (max 20-30mm)

special features:

nearly horizontal stroke-force (see catalogue)

closed loop function possible

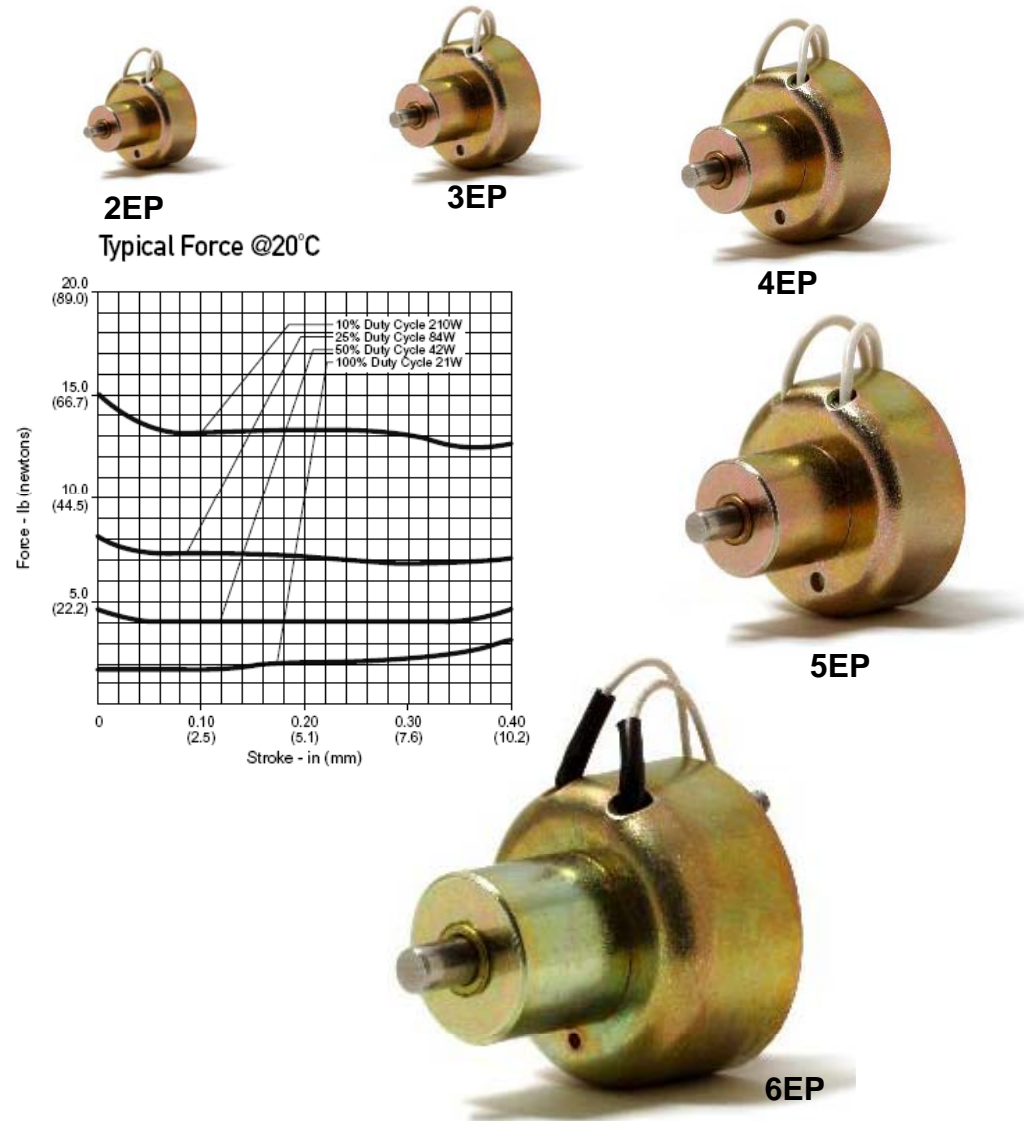



saia-burgess

Smart solutions for comfort and safety

Low profiles

applications & functions



Smart solutions for comfort and safety

- **application: sealer of blood guiding tube**
- **market segment: medical**

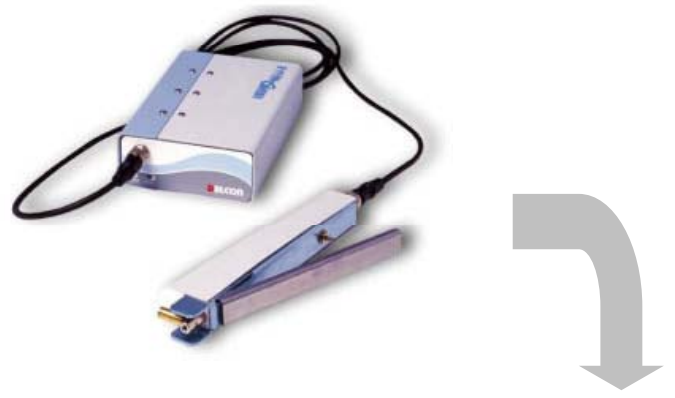

success factors:

very high force at short stroke
stand type available
sampling from preferred range
stock

- **function: tube sealing by pressing**
- **product: 5EC low profile**





Smart solutions for comfort and safety

- **application: coffee dispenser**
- **market segment: vending**



success factors:

very deep analyse of system
and special development

Proposal of new technology for
better (more accurate)
performance and lower cost
compared with actual
(Kendrion) version



- **function: dosing of coffee concentrate with special pump system**
- **product: special plungerless low profile**





saia-burgess

Smart solutions for comfort and safety

- **application: automatic slicing machine**
- **market segment: appliances**



success factors:

very high force at short stroke
stand type available
sampling from preferred range
stock

- **function: gear moving for connecting/disconnection slicing motor**
- **product: 5EC low profile**





Smart solutions for comfort and safety

- **application: lift for medical instruments in the operation room**
- **market segment: medical**



success factors:

standard product for this big (!)
size available

270N@10mm requested
possible

- **function: actuate a brake**
- **product: 8EC low profile**





Low profile solenoids:

main characteristics:

quick moving (ms range)

high forces (up to several hundred Newtons)

short linear stroke (max 20-30mm)

special features:

very high forces with short strokes

low height design

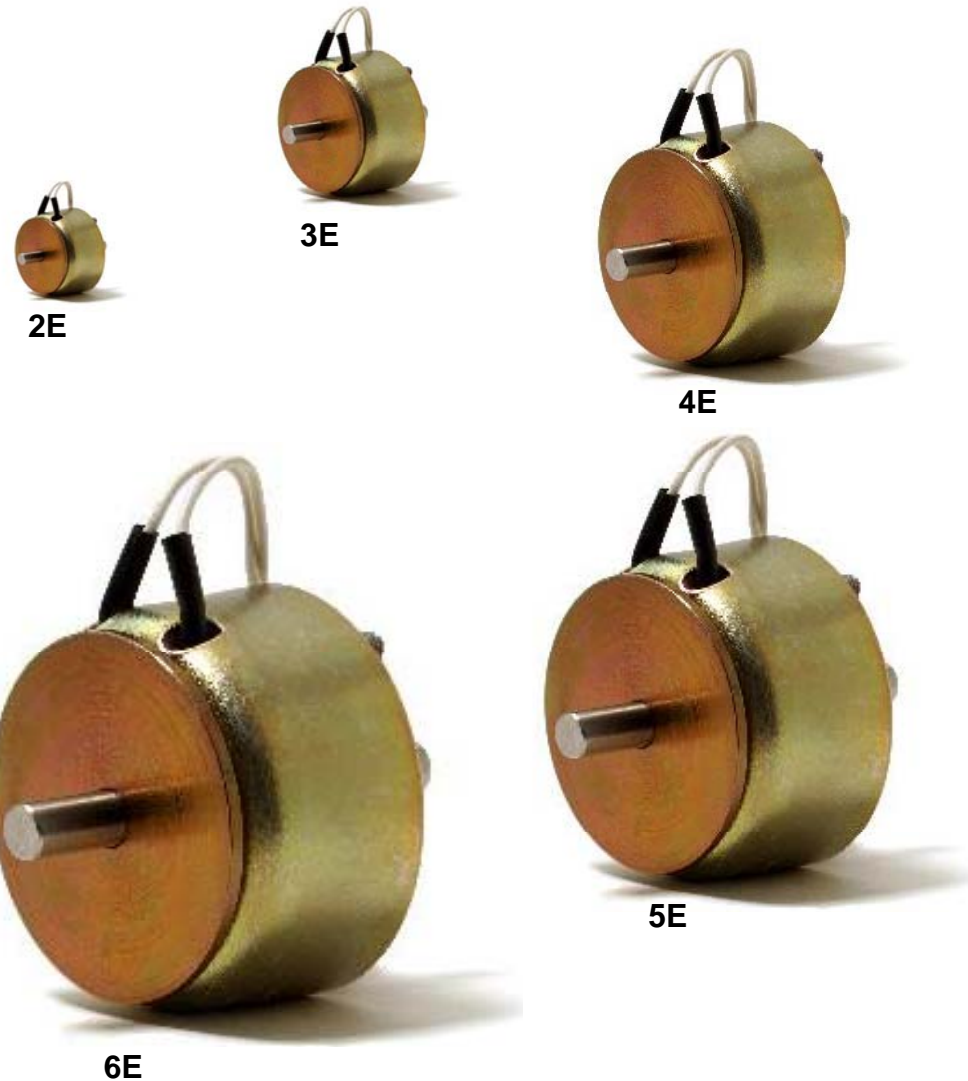



saiaburgess

Smart solutions for comfort and safety

Tubulars

applications & functions



Smart solutions for comfort and safety

- **application: document sorter**
- **market segment: industrial equipment**



success factors:

long life requirement (several millions cycles)

compact size with good performance ratio

- **function: move sorter to adress mail pallett to different direction**
- **product: STA tubular**





Tubular solenoids:

main characteristics:

quick moving (ms range)

high forces (up to several hundred Newtons)

short linear stroke (max 20-30mm)

special features:

very good size/performance ratio

long life (up to 25mil)

Push version available



13mm STA



20mm STA



26mm STA



push version



125M



150M



saia-burgess

Smart solutions for comfort and safety

rotary

applications & functions



Smart solutions for comfort and safety

- **application: laser equipment**
- **market segment: industrial equipment**



success factors:

rotary movement with little axial
linear movement

standard catalogue item, start
with preferred range

integrated return spring

▪ **function: optical security
shutter**

▪ **product: 2E rotary**

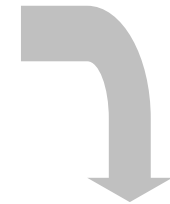

Rotary solenoids:

main characteristics:

quick moving (ms range)

high torque (up to several Nm)

short rotating stroke (max. 110°)

special features:

most economical rotating solution with an axial stroke component

large variety of angles

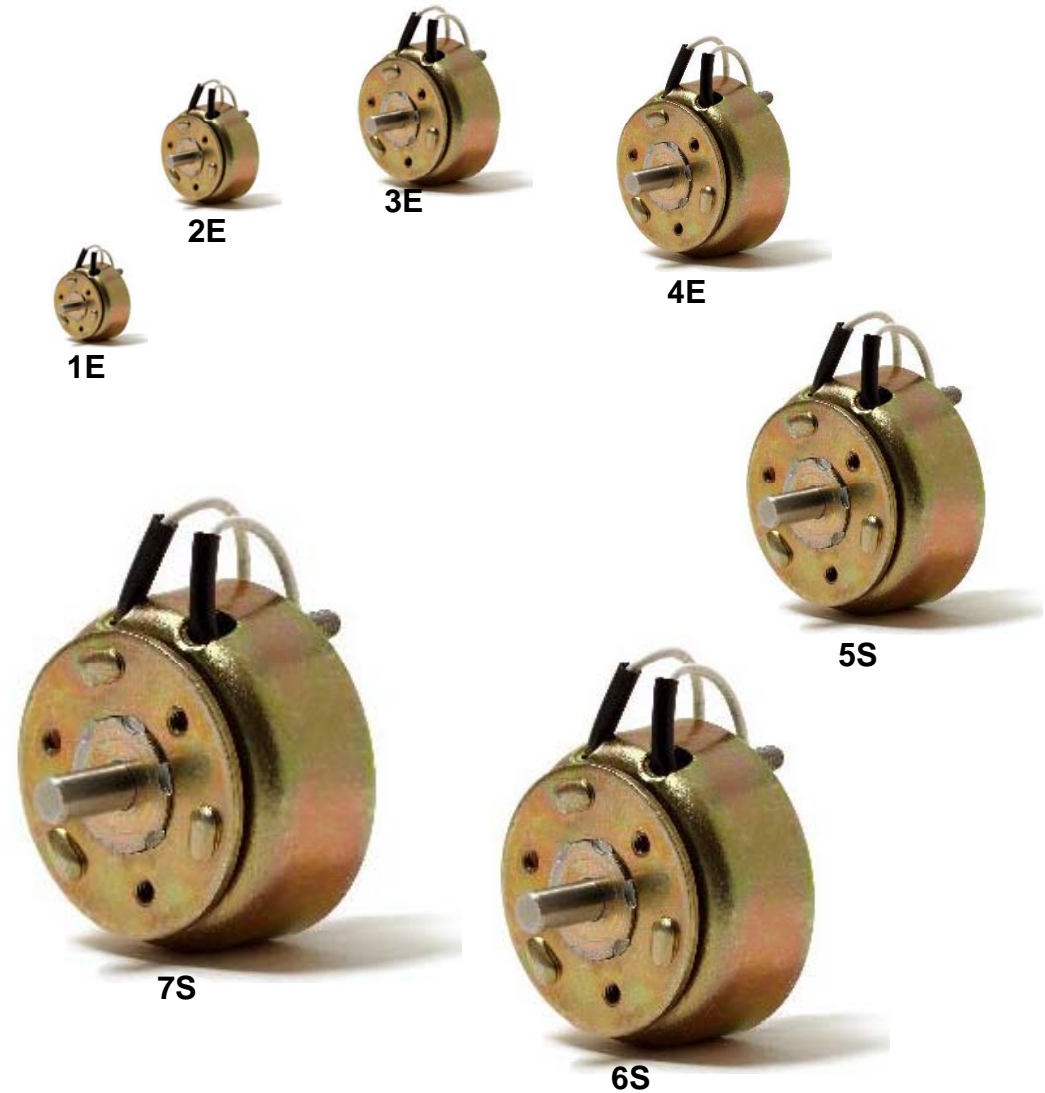



saia-burgess

Smart solutions for comfort and safety

BTA

applications & functions



Smart solutions for comfort and safety

- **application: postal sorter**
- **market segment: industrial equipment**

success factors:

Very quick movement (ms) with integrated spring return

Long life requirement (several million cycles)

few competition

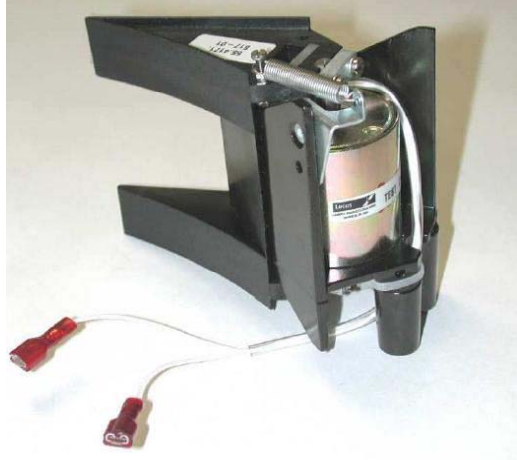

- **function: flap moving for mail flow diverting**
- **product: BTA**





Smart solutions for comfort and safety

- application: cash dispenser
- market segment: vending



success factors:
special bistable solution
Quick rotary movement up to 60°

- function: pull bank note out of deposit
- product: special BTA





BTA solenoids:

main characteristics:

quick moving (ms range)

high torque (up to 1,7 Nm)

short rotating stroke (45°)

special features:

very fast unidirectional
device

integrated spring return

100 million cycles





saia-burgess

Smart solutions for comfort and safety

Ultimag

applications & functions



Smart solutions for comfort and safety

- **application: laser machine**
- **market segment: industrial equipment**

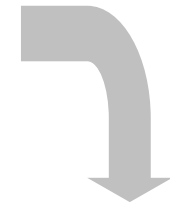

success factors:

bidirectional movement

quick movement (ms)

long life requirement (several million cycles)



- **function: mirror moving to create a line**
- **product: Ultimag**



Smart solutions for comfort and safety

Ultimag solenoids:

main characteristics:

- quick moving (ms range)
 - high torque (up to 1,5 Nm)
 - short rotating stroke ($\pm 25^\circ$)
-

special features:

- very fast bidirectional devise (with inverse of power supply polarity)
 - 100 million cycles
-

