

# PCD1.G5010-A20

## E-Line RIO 12DI, 4Rel, 12AI, 8AO

The E-Line RIO modules are controlled via RS-485 and enable decentralised automation using industrial quality components. The data point mix is specifically designed for applications in the HVAC sector.

Moreover, the compact design enables the use in electrical distribution boxes even in the most confined spaces. Installation and maintenance are facilitated by the local manual override for each output. Remote maintenance is also possible using the access to the manual override by the web interface in the Saia PCD® controller. Programming is also very efficient and fast using a complete FBox library with web templates.

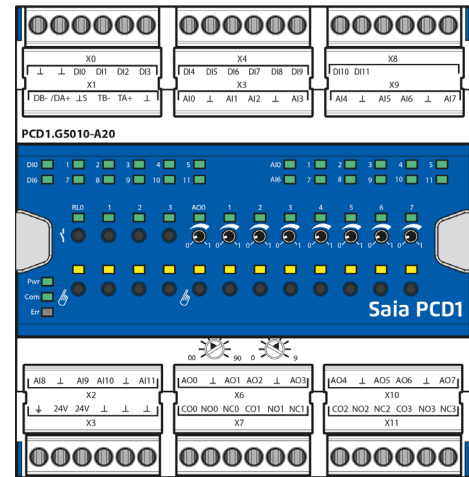

### Features

- Optimised S-Bus protocol for faster communication (4 × faster)
- Local override operating level via web panel or buttons on the module
- Specific I/O mix suitable for HVAC systems
- Easy programming using the FBox library and web templates
- Industrial hardware in accordance with IEC EN 61131-2
- Pluggable terminal blocks protected by flaps
- Electrically isolated RS-485 interface

### General technical data

#### Power supply

Supply voltage	24 VDC, -15/+20% max. incl. 5% ripple (in accordance with EN/IEC 61131-2)
Electrically isolated	500 VDC between power supply and RS-485
Power consumption	1.2...3 W

#### Interfaces

Communications interface	RS-485 with galvanic isolation Baud rate: 9,600, 19,200, 38,400, 57,600, 115,200 bps (Autobauding)
Address switch for S-Bus address	Three rotary switches 0...9 Address range 0...98
Terminating resistor	Integrated, can be activated via a wire jumper

#### General data

Ambient temperature	Operation: 0...+55 °C Storage: -40...+70 °C
---------------------	--

### Dimensions and installation

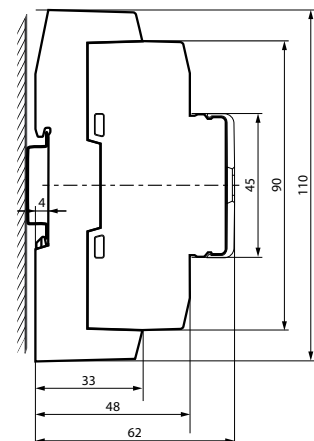
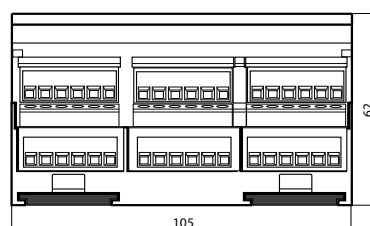
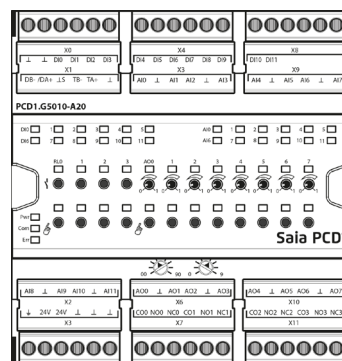

on a 35 mm top-hat rail (in accordance with DIN EN 60715 TH35)

Housing width 6 HP (105 mm)  
Compatible with electrical control cabinet (in accordance with DIN 43880, size 2 × 55 mm)

## Input/output configuration

### Digital inputs

Number	12
Input voltage	24 VDC, source operation (positive switching)
Switching level	Low: 0...5 V, High: 15...24 V
Input current	Typical 2 mA
Input filter time (DC)	Typical 8 ms

### Analogue inputs

Number	8
Galvanic separation	No
Signal range and measured values (configurable by FBoxes)	Voltage measurement ... 0 V ... +10 V -10 V ... +10 V Resistance ..... 0 Ω ... 2500 Ω 0 Ω ... 7500 Ω 0 Ω ... 300 kΩ NTC10k ..... 0 Ω ... 300 kΩ NTC20k ..... 0 Ω ... 300 kΩ Pt1000 ..... -50 °C ... +400 °C Ni1000 ..... -50 °C ... +210 °C Ni1000 L&S ..... -30 °C ... +140 °C
Maximum input voltage	+/- 20 V (independent of input configuration) voltages > 15 V / < -15 V, can result in incorrect values at other inputs
Input delay	Channel update 4 ms (all channels are updated during this time) Hardware input filter time Voltage measurement τ = 2.5 ms Resistance measurement τ = 8 ms Digital input filter 10 values

Mode	Resolution [bit]	Resolution [measured value]	Accuracy (at T <sub>Ambient</sub> = 25°C)	Display
Voltage 0...10 V	13	1.22 mV (linear) $R_{IN} = 220 \text{ k}\Omega$	0.3% of the measured value +/- 10 mV	0...1000 (standard) or user scaling
Voltage -10 V ...+10 V	12 + sign	2.44 mV (linear) $R_{IN} = 220 \text{ k}\Omega$	0.3% of the measured value +/- 10 mV	0...1000 (standard) or user scaling
Resistance 0...2500 Ω	12	0.50 ... 0.80 Ω Measuring current: 1.0 ... 1.3 mA	0.3% of the measured value +/- 3 Ω	0...25,000
Resistance 0...7500 Ω	13	0 .. 3000 Ω: 1 ..... 2 Ω 3000 .. 7500 Ω: 2 ..... 4 Ω Measuring current: 1.0 ... 1.3 mA	0.3% of the measured value +/- 8 Ω 0.3% of the measured value +/- 15 Ω	0...75,000
Resistance 0...300 Ω	13	0 .....15 kΩ: 1 .... 10 Ω 15 .....40 kΩ: 10 .... 40 Ω 40 .....70 kΩ: 40 ... 100 Ω 70 ... 100 kΩ: 100 ... 200 Ω 100 ... 300 kΩ: 0.2 ... 1.5 kΩ Measuring current: 1.0 ... 1.3 mA	0.3% of the measured value +/- 40 Ω 0.3% of the measured value +/- 160 Ω 0.5% of the measured value +/- 400 Ω 1.0% of the measured value +/- 800 Ω 2.5% of the measured value +/- 5.0 kΩ	0...3,000,000
NTC10k <sup>[2]</sup>	13	-40 .. +120 °C: 0.05 ... 0.1 °C	-20...+60 °C: +/- 0.6 °C -30...+80 °C: +/- 1.0 °C -40...+120 °C: +/- 2.8 °C	-400...1200 <sup>[1]</sup>
NTC20k <sup>[2]</sup>	13	-10 ... +80 °C: 0.02 .. 0.05 °C -20 .. +150 °C: < 0.15 °C	-15...+75 °C: +/- 0.6 °C -20...+95 °C: +/- 1.0 °C +95...+120 °C: +/- 2.5 °C +120...+150 °C: +/- 5.8 °C	-200...1500 <sup>[1]</sup>
Pt 1000	12	-50 .. +400 °C: 0.15 .. 0.25 °C Measuring current: 1.0 ... 1.3 mA	0.3% of measured value +/- 0.5 °C	-500...4000
Ni 1000	12	-50 .. +210 °C: 0.09 .. 0.11 °C Measuring current: 1.0 ... 1.3 mA	0.3% of measured value +/- 0.5 °C	-500...2100
Ni 1000 L&S	12	-30 .. +140 °C: 0.12 ... 0.15 °C Measuring current: 1.0 ... 1.3 mA	0.3% of measured value +/- 0.5 °C	-300...1400

<sup>[1]</sup> The RIO FBoxes transmit the value 0...300 kΩ.

<sup>[2]</sup> The temperature curves for NTC are not standardised and can differ depending on the NTC sensor manufacturer. With a linearisation FBox, a CSV file can be used to generate linearised values. The CSV file can be found on the support page (link see last page).

### Relay outputs

Number	4 changeovers
Switching voltage max.	250 VAC / 30 VDC
Switching current max.	4 A (AC1, DC1)
Contact protection	None
Local manual override	Override operation by button

## Input/output configuration

---

### Analogue outputs

Number	8	
Resolution	10 bit	
Signal range	0...10 V	
Local manual override	Manual control by button and potentiometer	
Protection	Short-circuit protection	
Resolution	9.77 mV	
Max. load at output	1 k $\Omega$ (10 mA at 10 V)	
Accuracy (at T <sub>Ambient</sub> = 25°C)	0.3% of the value +/- 10 mV	
Residual ripple	< 15 mVpp	
Temperature error (0°C...+55°C)	+/- 0.2%	
Output delay	Channel update	1 ms (all channels are updated in this time)
	Hardware output filter time	$\tau$ = 2.5 ms

### Terminal technology

Push-in spring terminals enable wiring with rigid or flexible wires with a diameter up to 1.5 mm<sup>2</sup>. A max. of 1 mm<sup>2</sup> is permitted with cable end sleeves.

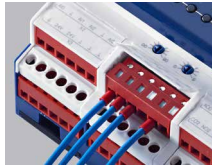

### Connection concept

The device is supplied by a 24 VDC voltage supply.

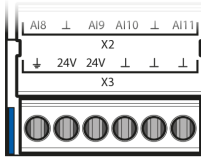

### Bus wiring

DB- and /DA+ terminals must be used for exchanging data between modules. The bus is through-wired by using one terminal per bus line in order to not interrupt the bus connection when removing the connector on modules.

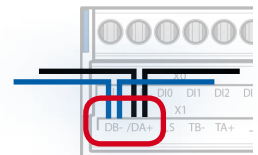

Flexible RS-485 cables with a cross section of no more than 0.75 mm<sup>2</sup> must be used for bus wiring. A cable cross section of 1.5 mm<sup>2</sup> is allowed per terminal.

The communication bus can be terminated with internal terminating resistors using wire bridges.

## Assignment overview

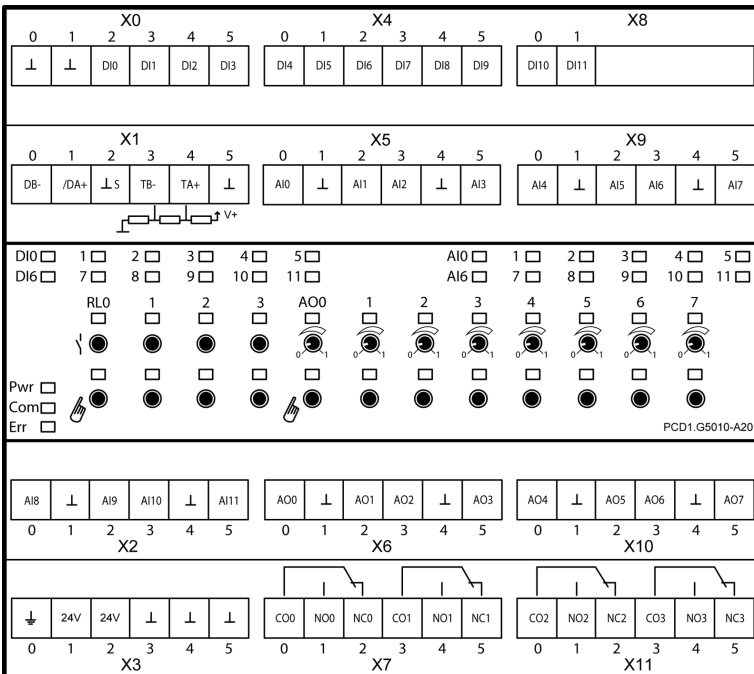

## Connection diagrams

### Digital input

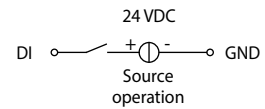

### Analogue input

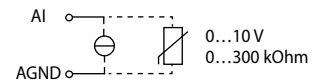

### Relay (changeover)

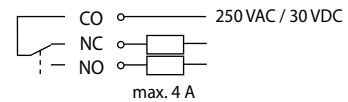

### Analogue output

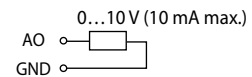

### Terminating resistor

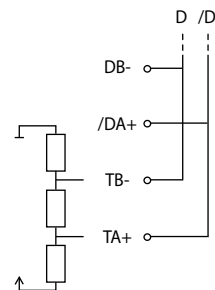

## Programming



The modules are addressed and programmed with Saia PG5® Fupla FBoxes. Web templates are available for the operation and visualisation of the manual override function.

### Fupla

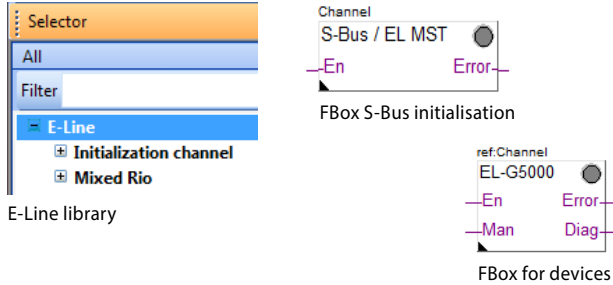

### Communication FBox

- ▶ Data exchange for I/O via optimised S-Bus
- ▶ Configurable save state for bus interruption or timeout
- ▶ Direct generation of the symbols
- ▶ Reading and writing of the status of the manual override status
- ▶ Direct compatibility with web macros



Further information, including which FBoxes are supported, Getting Started, etc., can be found on our support page [www.saia-support.com](http://www.saia-support.com)

### Web templates

Web templates are available for the operation and visualisation of the manual override function.

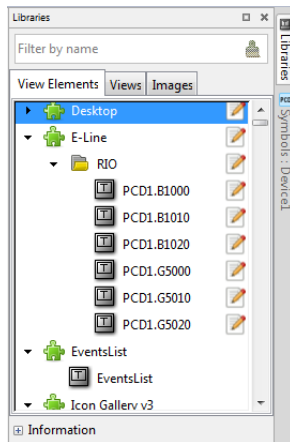

The inputs / outputs of the E-Line RIO modules can be addressed via the standard S-Bus. However the FBox from the E-Line library is used for the configuration of these modules. It is therefore recommended to use the optimised S-Bus protocol and the corresponding FBoxes from the E-Line library. Mixed mode operation is not recommended.

### Manual operation

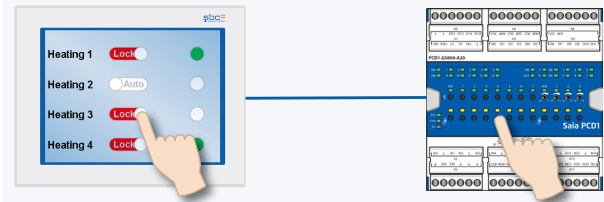

By using the local override function, commissioning can take place independently of the master station.

In addition, the manual operation can also be controlled remotely using a touch panel. If the bus line is cut off, the module keeps the manually set values. Traditional manual operation in the control cabinet door via potentiometers and switches can therefore be completely replaced by this solution.

Five operating modes can be selected for the manual operating function:

Operating modes	Description	Operation	
		at the module	via remote (S-Bus)
1	Manual operation deactivated	✗	✗
2	Operation permitted from the module only	✓	✗
3	Operation permitted from the module and limited operation from the panel. If manual operation is activated at the module, it cannot be reset from the panel.	✓	(conditional)
4	Unlimited operation from the panel and module	✓	✓
5	Panel operation (remote)	✗	✓



Depending on the application, reset of manually set values is allowed from a panel. To address this requirement, it is possible to deactivate or limit manual operation function.

## Order details

Type	Short description	Description	Weight
PCD1.G5010-A20	E-Line RIO 12DI, 4Rel, 12AI, 8AO	E-Line combined input/output module Manual priority operating level for all outputs Status LED for inputs and outputs Supply 24 VDC 12 digital inputs; 24 VDC (source operation) 4 relay changeover 250 VAC / 30 VDC, 4 A (DC1) 12 analogue inputs; 12 bit, 0...10 V, -10...+10 V, Pt/Ni 1000, NI1000 L&S, NTC, 0...2500 Ohm, 0...7500 Ohm, 0...300 kOhm 8 analogue outputs 12 bit, 0...10 V (10 mA max.) 1 interface RS-485 (S-Bus)	362 g
PCD1.K2026-005	E-Line labelling set 5 × 6 HP	E-Line cover and labelling set consisting of 5 × covers (6 HP = 105 mm) and labelling sheet for mounting in the automation control cabinet	365 g
PCD1.K2026-025	E-Line labelling set 5 × 6 HP m. L.	E-Line cover and labelling set with holes consisting of 5 × covers (6 HP = 105 mm) with holes for manual override operating level and labelling sheet for mounting in the automation control cabinet	365 g

### Saia-Burgess Controls AG

Bahnhofstrasse 18 | 3280 Murten, Switzerland  
T +41 26 580 30 00 | F +41 26 580 34 99  
www.saia-pcd.com

support@saia-pcd.com | www.sbc-support.com