

TRC-P Series Touchscreen Room Controllers

The TRC-P series controllers have been designed for climate control in room spaces with modern sharp slim line 3.5" colour touchscreen interface. The controllers have up to two heating and cooling temperature control stages, fan speed control, optional CO2 level and humidity control. The units can be in various climate control applications fan coil units, chilled ceiling and zone heating/cooling systems. The TRC-P series controllers have built-in 7-day schedule and real-time clock.

The controllers are available with wide range of input and output configurations. The controllers offers PI-control for accurate energy efficiency.

The devices are available with both Modbus RTU and BACnet MS/TP communication.



Features

- 24VAC/DC Power Supply
- 3.5" Backlit Touchscreen Display
- BACnet and Modbus Communication Models
- Flush Mounting in the US, UK or EURO Wall Mounting Box
- Built-In Temperature Sensor, up to 2 x Remote NTC10 Sensors
- Wide Range of Input and Output Configurations
- Digital Input for Overrides
- Control of up to four control stages; Boost, Comfort, ECO and OFF Control Modes
- 7-Day Schedule and Real-Time Clock for Switching Between the Operating Modes
- Automatic Summer/Winter Time Change-Over

Product Selection Table

Ordering guide		Type	0	1	2	3	4	5	6
0	Touchscreen room controllers		6001			2			
1	Device type	Room controller, 2RI, 1DI, 3AO, Schedule	TRC-P-3A	N					
		Room controller, 1RI, 1DI, 2AO, 3RO, 0.5A, Schedule	TRC-P-2A3R	P					
		Room controller, 1RI, 1DI, 2AO, 3RO, 7A, Schedule	TRC-P-H-2A3R	Q					
		Room controller, 2RI, 1DI, 1AO, 2DO, Schedule	TRC-P-1A2T	R					
		Room controller, 2RI, 1DI, 1AO, 3RO, 1RO, Schedule	TRC-P-1A4R	S					
		Room controller, 2RI, 1DI, 3RO (7A), 2DO, Schedule	TRC-P-H-3R2T	T					
2	Communication	Modbus	-MOD		M				
		BACnet	-BAC		B				
3	Power supply	24 Vac/dc	-24			2			
4	Additional measurements	No additional measurement					0		
		Relative humidity	-RH				1		
		CO ₂	-CO ₂				2		
		Relative humidity and CO	-RH-CO ₂				3		
5	Advanced options	No advanced options						0	
		0...10 Vdc input(s) (replaces RI input(s))	-AI					1	
6	Body colour	Chrome							0
		White (RAL 9010)	-W						W
		Black (RAL 8022)	-B						B

Technical Data

Power Supply	Power:	24VAC/DC -10%/+15%, 80mA	
Display	Touchscreen	3.5" Backlit Touchscreen, 320 x 480 pixels, 255K colours	
Signal Outputs	Analogue Outputs	TRC-P-3A: 3 x 0..10V < 5mA TRC-P-2A3R: 2 x 0..10V < 5mA TRC-P-1A2T/TRC-1A4R: 1 x 0..10V < 5mA	
	Relay Outputs	TRC-P-2A3R: 3 x 0.5A (res.) at 230VAC TRC-P-H-2A3R/TRC-H-3R2T: 3 x 7A (res.) / 2.2A (inductive) at 230VAC / 3 x 7A (res.) / 1.3A (inductive) at 115VAC TRC-P-1A4R: 4 x 0.5A (res.) at 230VAC.	
	Digital Outputs	TRC-P-1A2T/TRC-P-H-3R2T: 2 x 24VAC 1A Triac (switching to 0V). Note: Requires 24VAC power supply.	
Signal Inputs	Built-In Sensor	0..50°C (32..122°F) ±0.5°C (0.9°F) @ 25°C (77°F)	
	External Sensor Inputs	TRC-P-3A/1A2T/1A4R/3R2T: 2 x External NTC10K3 Sensors (RI1 & RI2) TRC-P-2A3R: 1 x External NTC10K3 Sensor (RI1) Note: Resistive Inputs can also act as Volt-Free Digital Inputs	
	Digital Input	1 x Digital Input, Volt-Free Contact, Impedance <1KOhm	
Optional Sensing Characteristics	Carbon Dioxide (CO ₂ Models)		
	Range	0..5000ppm CO ₂	
	Accuracy	± 50ppm + 3% of the reading @ 25°C (@77°F)	
	Technology	Auto Calibrating; Patented Non-Dispersive Infrared (NDIR)	
	Non-Linearity	<1% FS	
	Warm-Up Time	<20 seconds	
	Response Time	2 minutes	
Humidity (RH Models)	Range	0..100%rH	
	Accuracy	±2% rH (within 20..80% rh)	
Communication	Modbus (-MOD models)		
	Protocol	Modbus RTU	
	Interface	RS485; maximum 63 devices	
	Addressing	1..247 via Touchscreen	
	Communication	9k6/19k2/38k4/57k6/76k8 Baud; Parity None/Even/Odd, 1 or 2 Stop Bits (adjustable through Touchscreen)	
	BACnet (-BAC models)		
	Protocol	BACnet MS/TP	
	Interface	RS485; maximum 63 devices	
	MAC Addressing	0.127 via Touchscreen	
	Device ID	Default 651000 + MAC Address, Adjustable	
	Communication	9k6/19k2/38k4/57k6/76k8 Baud; Parity None/Even/Odd, 1 or 2 Stop Bits (adjustable through Touchscreen)	
	Connections	Terminal Connections (Power Supply & Analogue Outputs)	Solid and Stranded Cable Maximum Size: Solid: 0.05-2.5mm ² , Stranded: 0.05-1.50mm ² / 14 to 30 AWG (UL) Rising Clamp: Size 2.5 x 2.2mm
		Terminal Connections (Comms and Inputs)	Solid and Stranded Cable; 90° Angle for Wiring Maximum Size: 0.05 to 1.5mm ² (EN ISO) / 14 to 30 AWG (UL) Rising Clamp: Size 2.5 x 1.9mm
	Environmental Conditions	Operating	
Temperature		0°C...+50°C (32..122°F)	
Humidity		0...95%rh (non-cond.)	
Storage			
Temperature		-30°C...+70°C (-22..158°F)	
Humidity		0...95%rh (non-cond.)	

Standards	CE Conformity	CE Directive 2004/108/EC (EMC), 2006/95/EC (LVD) EN61000-6-3: 2001 (Generic Emission) EN61000-6-1: 2001 (Generic Immunity) EN60730-1:2016 (Low Voltage) EN6100-4-2/4/5/11 (ESD, Transient, Surges, Interruptions)
	Degree of Protection	IP20
Housing	Housing Material	Polycarbonate Plastics, Self Extinguishing, Black and Chrome W-Option: White Enclosure - Black Front B- Option: Black Enclosure - Black Front
	Mounting	Wall or Junction Box Mounting
	Dimensions	W88 x H112 x D43mm; Flush: W88 x H112 x D14.5mm
	Weight	220g

TRC-P-3A Wiring Connections

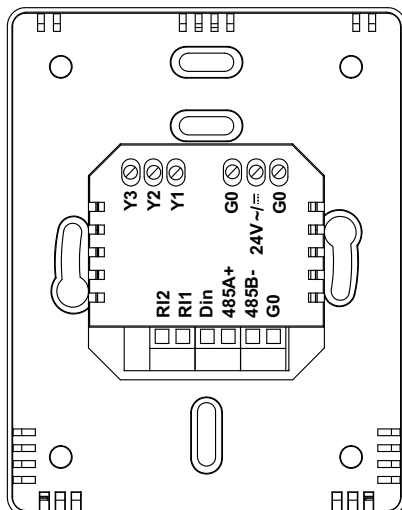

CONN	DESCRIPTION
Y1	0..10Vdc Analogue Output 1 - default fan speed
Y2	0..10Vdc Analogue Output 2 - default heating stage 1
Y3	0..10Vdc Analogue Output 3 - default cooling stage 1
24V	24Vac/dc Supply
G0	0V Common
R11	Remote NTC10 Temperature Sensor Input 1 (0-10V with AI option)
R12	Remote NTC10 Temperature Sensor Input 2 (0-10V with AI option)
Din	Volt-Free Digital Input Contact (dry contact)
485A+	Modbus / BACnet MS/TP RS485 A+ Connection
485B-	Modbus / BACnet MS/TP RS485 B- Connection
G0	0V Common

WARNING: Switch off the power before any wiring is carried out.

TRC-P-2A3R Wiring Connections

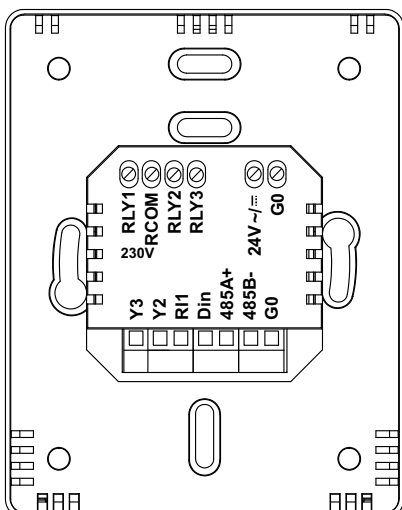

CONN	DESCRIPTION
RLY1	2A3R: 230V 0.5A Relay - Fan Speed 1 H-2A3R: 230V 7A Relay - Fan Speed 1
RLY2	2A3R: 230V 0.5A Relay - Fan Speed 2 H-2A3R: 230V 7A Relay - Fan Speed 2
RLY3	2A3R: 230V 0.5A Relay - Fan Speed 2 H-2A3R: 230V 7A Relay - Fan Speed 2
RCOM	Relay Common
24V	24Vac/dc Supply
G0	0V Common
Y2	0..10Vdc Analogue Output 2 - default heating stage 1
Y3	0..10Vdc Analogue Output 3 - default cooling stage 1
R11	Remote NTC10 Temperature Sensor Input 1
Din	Volt-Free Digital Input Contact (dry contact)
485A+	Modbus / BACnet MS/TP RS485 A+ Connection
485B-	Modbus / BACnet MS/TP RS485 B- Connection

CONN	DESCRIPTION
G0	0V Common

WARNING: Switch off the power before any wiring is carried out.

TRC-P-1A2T Wiring Connections

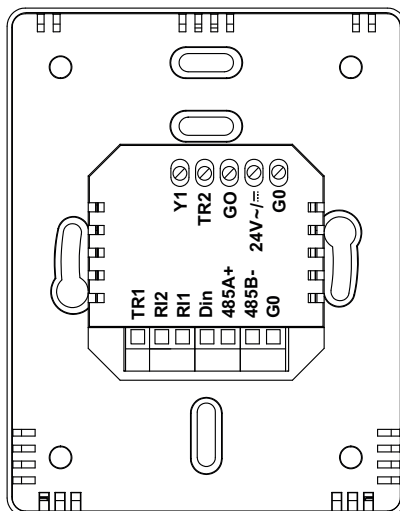

CONN	DESCRIPTION
Y1	0..10Vdc Analogue Output - default fan speed
TR1	24Vac 1A Triac (switched to 0V)- default Heating PWM
TR2	24Vac 1A Triac (switched to 0V) - default Cooling PWM
24V	24Vac/dc Supply
G0	0V Common
R11	Remote NTC10 Temperature Sensor Input 1 (0-10V with AI option)
R12	Remote NTC10 Temperature Sensor Input 2 (0-10V with AI option)
Din	Volt-Free Digital Input Contact (dry contact)
485A+	Modbus / BACnet MS/TP RS485 A+ Connection
485B-	Modbus / BACnet MS/TP RS485 B- Connection
G0	0V Common

TRC-P-1A4R Wiring Connections

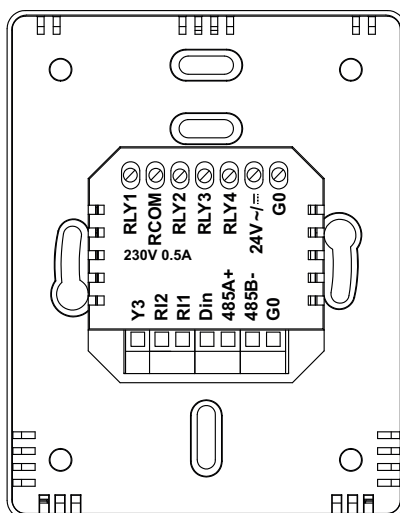

CONN	DESCRIPTION
RLY1	230V 0.5A Relay - Fan Speed 1 / On-Off Valve
RLY2	230V 0.5A Relay - Fan Speed 2
RLY3	230V 0.5A Relay - Fan Speed 3
RCOM	Relay Common
RLY4	230V 0.5A Relay - On-Off Valve
24V	24Vac/dc Supply
G0	0V Common
Y3	0..10Vdc Analogue Output 3 - default cooling stage 1
R12	Remote NTC10 Temperature Sensor Input 2 (0-10V with AI option)
R11	Remote NTC10 Temperature Sensor Input 1 (0-10V with AI option)
Din	Volt-Free Digital Input Contact (dry contact)
485A+	Modbus / BACnet MS/TP RS485 A+ Connection
485B-	Modbus / BACnet MS/TP RS485 B- Connection
G0	0V Common

TRC-P-H-3R2T Wiring Connections

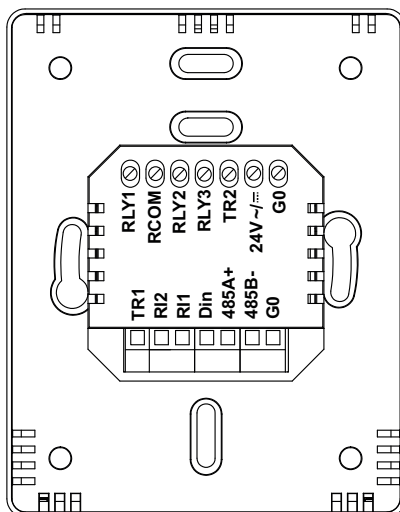

CONN	DESCRIPTION
RLY1	230V 7A Relay - Fan Speed 1 / On-Off Valve
RCOM	Relay Common
RLY2	230V 7A Relay - Fan Speed 2
RLY3	230V 7A Relay - Fan Speed 3
TR2	24Vac 1A Triac (switched to 0V) - default Cooling PWM
24V	24Vac/dc Supply
G0	0V Common
TR1	24Vac 1A Triac (switched to 0V)- default Heating PWM
RI2	Remote NTC10 Temperature Sensor Input 2 (0-10V with AI option)
RI1	Remote NTC10 Temperature Sensor Input 1
Din	Volt-Free Digital Input Contact (dry contact)
485A+	Modbus / BACnet MS/TP RS485 A+ Connection
485B-	Modbus / BACnet MS/TP RS485 B- Connection
G0	0V Common

TRC-P Series User Interface

The figures below illustrate some of the TRC-P controller user displays. The multi-colour LCD screen is touch sensitive, easy to adjust and illustrates clearly the plant status information.

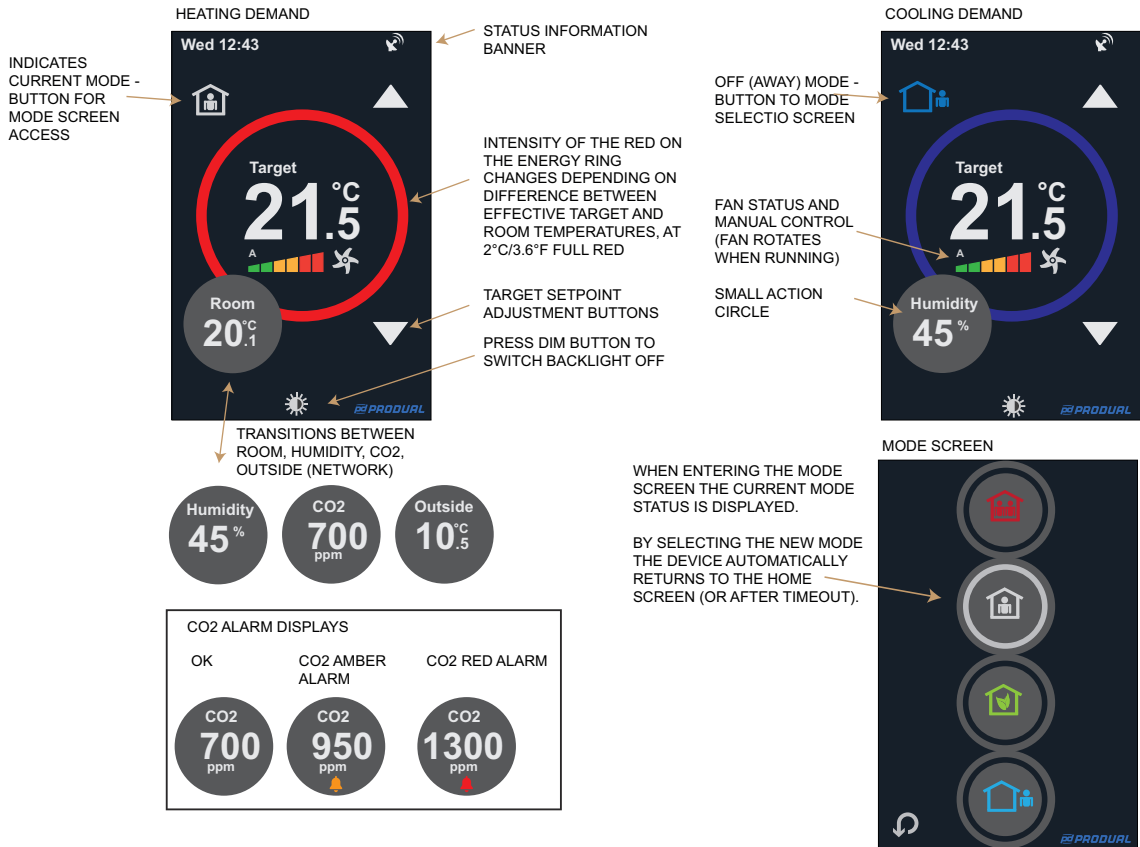

The colour of the 'Energy Ring' indicates the heating/cooling demand. The 'Energy Ring' is white at 'deadzone'. The density of red/blue on the 'Energy Ring' modulates based on how far from the Effective Heating/Cooling Setpoint the temperature is. When the difference is 2°C/3.6°F the 'Energy Ring' is at full density.

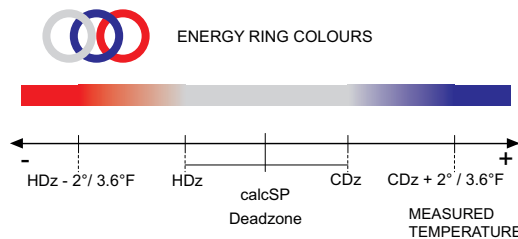

Touchscreen

The TRC-P controller home screen has a number touch sensitive areas that allow the device settings to be changed.

- UP and DOWN arrows; to alter the current control target setpoint temperature
- SCREEN DIM ICON; dims the screen backlight/ switches backlight off
- SMALL ACTION CIRCLE (that contains current room and/or floor temperature, CO2, humidity etc); allows access to FURTHER SETTINGS AND INFORMATION screen; password protected
- FAN SPEED ICON; when FAN display is enabled, the fan ICON can be used to control the fan speed
- COMFORT/ECO/OFF/BOOST ICON; used to select between COMFORT/ECO/OFF/BOOST modes. When selected, the MODE SELECTION screen is displayed and can be used to select the mode.

Programming Times and Targets

The TRC-P controllers have up to five programmable time switching times that can be configured to switch between COMFORT / ECO / OFF / BOOST modes. The times and targets can be set for individual weekdays or the thermostat can be switched 5+2 mode where the targets are set for WEEKDAYS or WEEKENDS.

The SCHEDULE OVERVIEW screen shows the current switching targets. By selecting the day it is possible to adjust the switching times and targets of the device.

NOTE: Switching from the 7 DAYS mode to 5+2 DAYS mode will set all weekday/weekend to the group settings. When returning back to 7 DAYS mode the setting are required to be re-entered for each day.

A copy function is available to copy times and target temperatures from one day (or group) to other day.

SETTING PROGRAM SCHEDULES

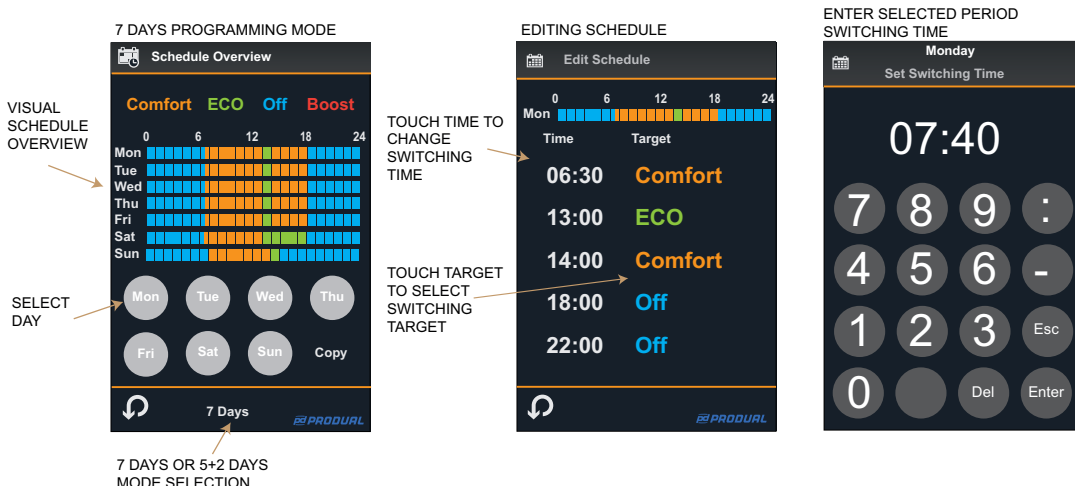

Touchscreen Backlight

The touchscreen backlight level can be adjusted through the maintenance mode. During the normal operation after 30 seconds of inactivity, the touchscreen dims to the "stand-by" level set. If the backlight level is set to 0, the screen backlight switches off.

By pressing the DIM icon when the screen is active the screen is immediately dimmed to the "stand-by" level. Pressing the DIM icon when the device is in the "stand-by level", switches the backlight OFF.

The screen backlight is automatically activated when it is touched.

Further Settings and Information

The FURTHER SETTINGS screen shows additional user settings options on the TRC controllers:-

- LOCK icon is used to lock the thermostat. Number of different lock modes options exist.
- CLEANING icon is used to enable timed (30 seconds) cleaning mode.
- COG WHEEL icon allows entry to the maintenance mode.
- CLOCK icon is used to set the time.
- TIME PROGRAMME ICON is used to set the switching times.
- COG WHEEL icon allows entry to the maintenance mode.

FURTHER SETTINGS screen is protected by STAFF ACCESS code. As default the STAFF CODE is set as '0000' and no password is required to enter the FURTHER SETTINGS screen.

FURTHER SETTINGS AND INFORMATION

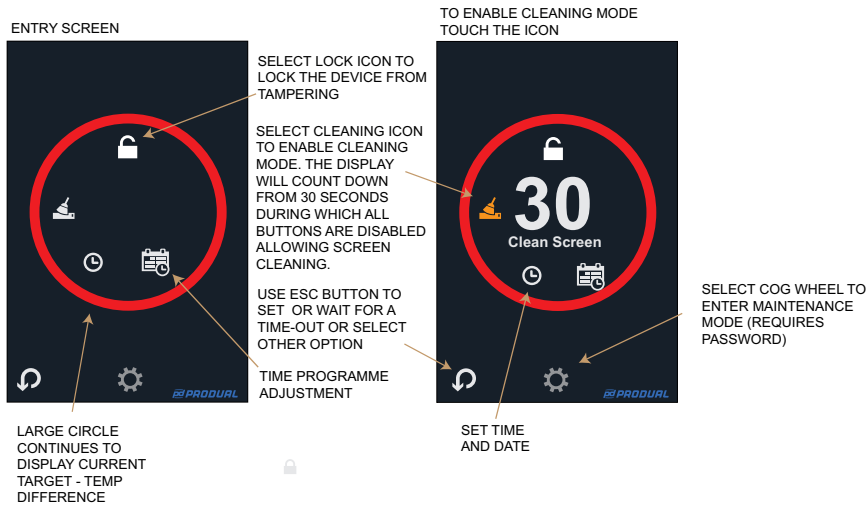

Temperature Control Loop Operation

The controllers can have up to two heating stages and cooling stages (as default one heating stage and one cooling stage), and can also carry out automatic change-over from heating to cooling via digital input / temperature measurement / network.

This allows various control configurations:-

- One/Two Stage Heating Control
- One/Two Stage Cooling Control
- One/Two Stage Heating and One/Two Stage Cooling Control (up to three outputs)
- One Stage Heating/Cooling Control (Change-Over)

The controller modulates the heating and cooling demand outputs according to the calculated setpoint and the current temperature. The control can be either P-control or PI-control. The calculated setpoint consists sum of Nominal Setpoint (nSP) and the user setpoint adjustment (SPA).

As default for TRC-3A/2A2R, heating stage 1 output is linked to Y2 for modulating 0..10Vdc control, cooling stage 1 is linked to analogue output Y3. With TRC-1A2T/H-3R2T, heating stage 1 is linked to DO1 PWM control and cooling stage 1 is linked to DO2 PWM control.

It is possible to set the control loop outputs to direct/reverse, which reverses the control output (valve) running direction (valve drives from 100% to 0%). This can be configured individually for each stage in the Configuration Parameters.

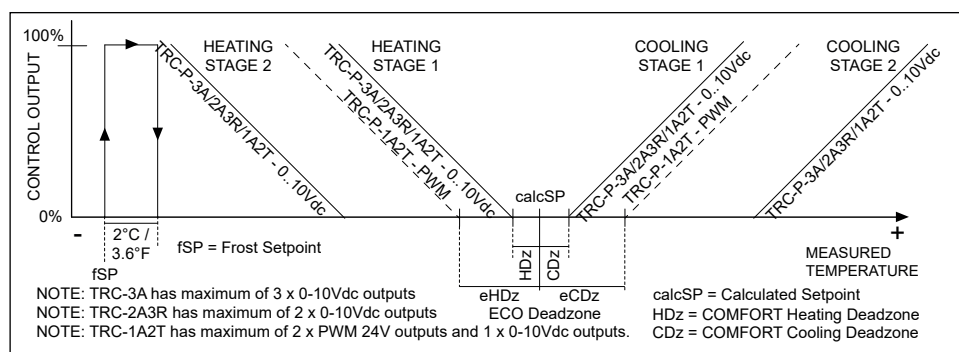

Between heating and cooling stage 1 is a 'deadzone'. With P-control in the 'deadzone' the cooling and heating loop demand is 0%. With PI-control, if the temperature remains in the 'deadzone' for a prolonged period, the heating/cooling demand ramps to 0%. The 'deadzone' allows the temperature to fluctuate around the setpoint without heating or cooling valves starting to open. The TRC has a built-in lock that prevents cooling and heating demands to be on simultaneously.

The 'deadzone' has an individual settings (HDz and CDz) for both heating and cooling side allowing asymmetrical setting. E.g. in some cases it is important that the cooling starts to respond faster than heating when the temperature deviates away from the setpoint.

Note: Conceptually calcSP - HDz is effective Heating Setpoint and calcSP + CDz is Effective Cooling Setpoint. For the user it is easier to set and display a single setpoint and the 'deadzone' limits are set during the commissioning to provide effective heating and cooling setpoints..

The target temperature is typically adjusted by the user by pressing UP & DOWN buttons. The target temperature/deadzone is changed in different operating situations as follows;

- COMFORT MODE; target temperature as adjusted by the user (or via the networked system) and displayed on the screen. The calculated target setpoint (calcSP) consist of the Nominal Setpoint plus the user adjustment (SPA) set via the screen. The user setpoint adjustment is limited by the Setpoint Adjust Max/Min settings (as default +/-3°).
 - ECO MODE; target Nominal Setpoint remains the same. The user adjustment (SPA) is disabled and the 'deadzone' settings are expanded to Night Heating Deadzone and Night Cooling Deadzone.
 - OFF MODE; the device controls to Frost Setpoint (fSP). The user adjustment (SPA) is disabled.
- NOTE: If activated, the High/low Limit Control shifts the effective target temperature (calculated setpoint) as required.**

Heating / Cooling Change-Over

The main temperature control loop heating stage 1 and cooling stage 1 can be forced to operate in heating or cooling mode using the change-over function. The change-over is carried out using digital input, temperature measurement or over the network. This allows the same pipe works to be used for both heating and cooling in different seasons.

The change-over function is activated if it is selected for the DI1.RI1/RI2.

With digital input the change-over is activated when the input is activated. Over the network the change-over can be activated by setting the change-over parameter on.

High/Low Limit Control (Reset Control)

If an external NTC10 sensor is fitted (to RI1 or RI2) and the corresponding high/low limit input has been enabled, the controller can carry out high limit and/or low limit control. In high limit control, if the external temperature exceeds the High Limit setpoint, the main control setpoint is reduced by the amount set in the Limit Ratio per degree. E.g. if the Limit Ratio is 2, every degree that the external temperature exceeds the High Limit setpoint, the target (setpoint) is reset by 2 degrees.

Note: RI2 is not available with TRC-P-2A3R.

The Low Limit control works in reverse. If the external temperature drops below the Low Limit setpoint, the main control setpoint is increased by the amount of the ratio for every degree below the Low Limit setpoint.

The setpoint reset amount follows the formula:-

$$\text{Setpoint_Reset} = (\text{Limit_Setpoint} - \text{Temperature}) * \text{Limit_Ratio}$$

NOTE: The target setpoint on the display is not changed during the limitation. The limit icon indicates active limitation. To see the effective limited setpoint enter Controller Status and Information display.

Note: The limit function is enabled by setting the Limit Ratio parameter (as default 0.0 = disabled).

Note: In OFF mode high/low limit function is disabled.

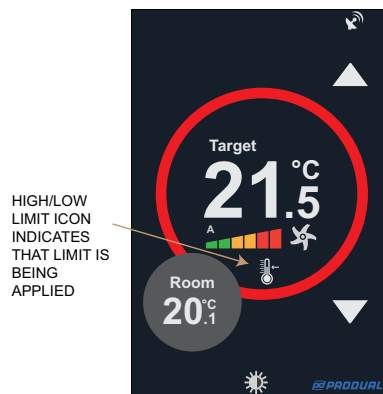

Mode Button and Screen

By touching the MODE BUTTON on the HOME SCREEN, the device enters to the MODE SCREEN. From the MODE SCREEN the operating mode of the controller can be selected.

The possible selections for the MODE screen are:-

- BOOST MODE
- COMFORT MODE
- ECO MODE
- OFF MODE

After selecting the Mode the device automatically returns to the HOME SCREEN. If no buttons are pressed the device returns automatically after a timeout. Alternatively the return button can be pressed to return.

The Mode button has the following configuration options:-

- Mode Display Only
- Mode Selection and Display (default)

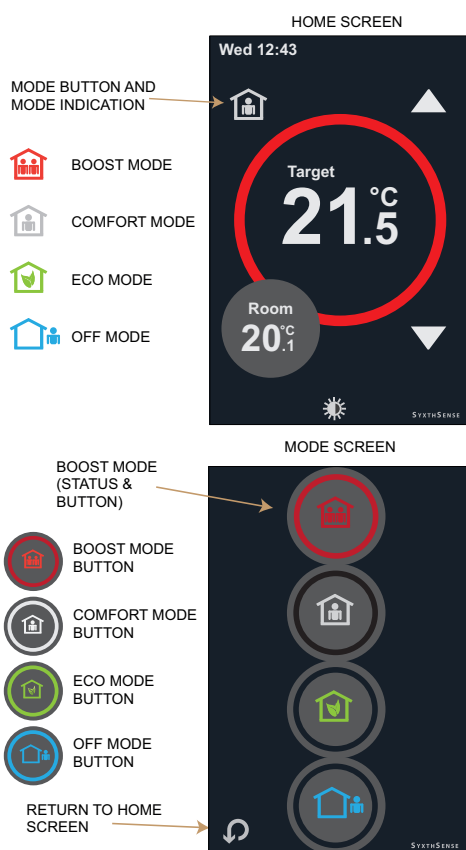

ECO Mode

The device can be switched to ECO mode via network, via digital input (e.g. PIR) or via the touchscreen.

In the ECO mode the controller starts to control to ECO Heating/Cooling Deadzone and the user setpoint adjustment (SPA) is removed.

In the ECO mode the CO2 and Humidity loops are switched to 0%.

The ECO mode can be selected/and cancelled using the MODE BUTTON (if enabled), The ECO mode is also indicated by the not showing the setpoint adjustment buttons.

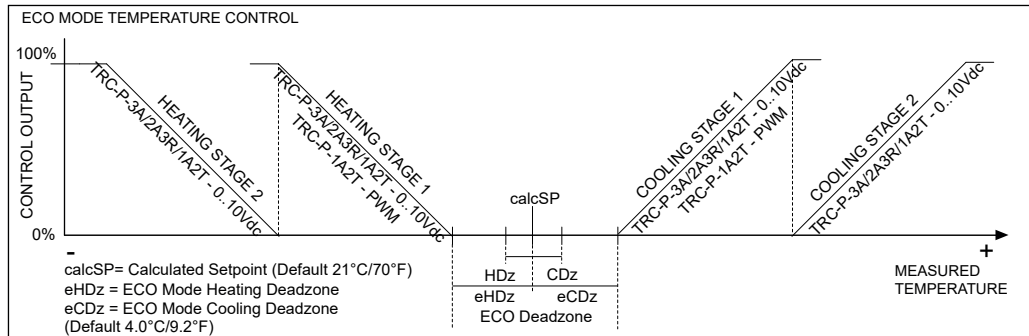
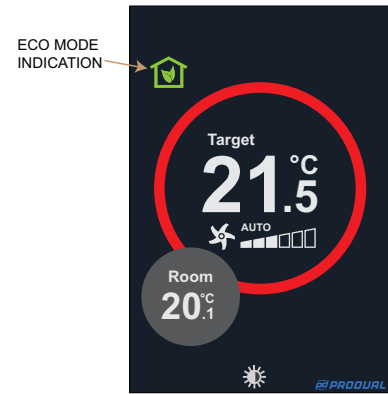

Note: If the 7 Day Schedule has been activated, the device starts to use the operating mode set at the next switching point (e.g. if the next switching point is COMFORT MODE, the devices returns to COMFORT mode).

OFF Mode

The controller can be switched to OFF mode via digital volt-free input (e.g. PIR), via the MODE BUTTON or via the communication network (system configuration).

In the OFF mode all temperature/CO2/humidity control outputs are switched off to 0% level.

When in OFF mode if the temperature drops below the OFF FROST Setpoint, the frost protection is activated, the SNOWFLAKE icon is displayed on the screen and the heating stages are switched to 100% and the fan speed output is switched to 33%. When the temperature exceeds the OFF FROST setpoint plus 2 degrees, the frost condition is deactivated.

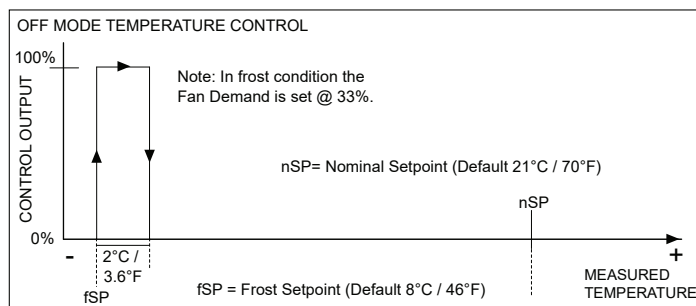
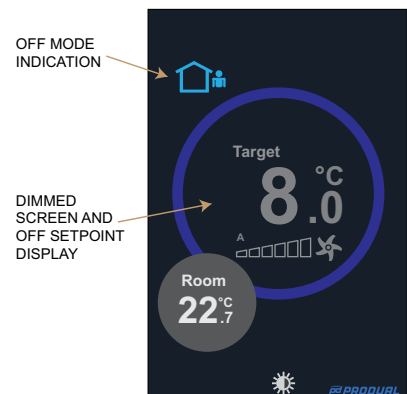

Note: If the 7 Day Schedule has been activated, the device starts to use the operating mode set at the next switching point (e.g. if the next switching point is COMFORT MODE, the devices returns to COMFORT mode).

Boost Mode

Boost mode can be activated through the MODE button. The Boost mode can be used e.g. to boost the temperature in the morning, or increase ventilation on high CO2 measurement.

The boost mode has Boost Target parameter that selects the target setpoint that the boost mode applies to. The target options are:-

- Temperature Setpoint (default)
- CO2 Setpoint
- Humidity Setpoint
- Dehumidity Setpoint
- Fan Demand
- Aux Setpoint

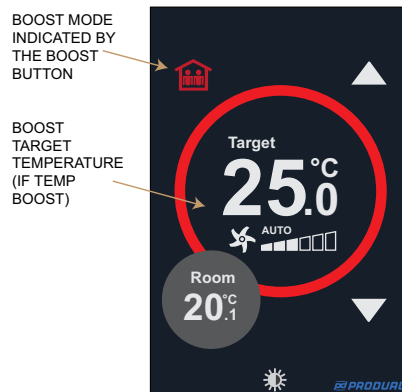

In addition the Boost Mode has boost target setpoint (as default 25.0). When the Boost mode is activated the selected setpoint is changed to the Boost Target. E.g in case of temperature heating boost, the target setpoint is increased. In case of CO2 boost the CO2 target setpoint is reduced.

Boost Mode has also built in timer. By setting the Boost Time to 1 to 480 minutes, this is the maximum Boost time. By setting the Boost Time to 'Permanent' there is no maximum Boost Time.

The boost mode continues to run until Maximum Boost Time has been reached, or if the Measurement reaches the Boost Target.

NOTE: The target for the temperature boost can be above or below the current setpoint. The fan boost target level is selectable between 1-100%.

The Boost Mode is also cancelled when the time reaches the next switching point on the 7-Day schedule regardless of the Boost Time or Current Measurement. Please note that at the next switching time the target (COMFORT/ECO/OFF/BOOST) must be different from the target in the current period in order to time to count as switching point.

NOTE: Digital Input can also be configured to activate the Boost.

Fan Speed Control

Fan speed control logic adjusts the fan speed based on the demand from 0% to 100%. The fan speed can be configured to follow different control loop outputs using the Fan Speed Source configuration parameter. The options are:-

- HEATING 1 AND COOLING 1 STAGE (Default)
- HEATING STAGE 1
- COOLING STAGE 1
- HEATING AND COOLING STAGE 2
- HEATING STAGE 2
- COOLING STAGE 2
- CO2 LOOP
- HUMIDITY LOOP
- DE-HUMIDITY LOOP
- MAXIMUM VAV; Maximum of Cooling Stage 1 and CO2 Loops
- MAX TEMP/HUM; Maximum of Heating Stage 1, Cooling Stage 1 and Humidity Loops

As default the fan speed control is configured to follow the Heating and Cooling Stage 1. This means that e.g. if Heating Stage 1 output is 55%, and the minimum fan level is set to 0%, the fan speed loop output is also 55%.

Minimum Fan Level parameter is used to set the minimum fan speed during the operation in COMFORT mode. The fan demand is scaled between the Minimum Fan Level and Maximum (100%) - see diagram below for example. The fan speed is 0% in the deadzone area unless Fan Off Delay is set to 0 = Indefinite (default - the fan remains at Minimum Fan Level in deadzone area).

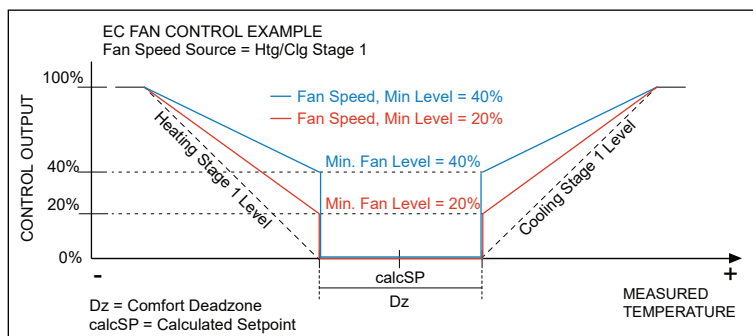

The Fan Off Delay defines time how long the fan overruns in the deadzone (after no demand). E.g. by setting the Fan Off Delay to 30 seconds, the fan switches off after the Htg/Clg Stage 1 demand has remained within the deadzone for 30 seconds (example above).

If maximum speed is required to be set for the fan, this is configured by setting the maximum level in the analogue output (Y1, Y2, Y3) scaling. As default fan speed is configured for Y1.

In ECO mode the Fan Speed control follows the same principle as in the COMFORT mode. In OFF mode the fan is Off unless frost has been detected in which case the fan output is set to 33%.

Automatic Fan Speed Display

Fan speed can be displayed on the screen using coloured bar indicating the speed and rotating fan icon. The display is enabled through the Fan Speed Display parameter. Options are:-

- NONE; no display (Default)
- NO INPUT; no user adjustment
- 0-1; Off/On
- 0-1-2; 2-Speed
- 0-1-2-3; 3-Speed
- 0-1-2-3-4-5-6; 6-Speed



When in Automatic control 'A' is displayed above the coloured bar. The number of bars displayed depends on the fan speed - switching levels described above.

Manual Fan Speed Override

The Fan Speed Display parameter is used to configure Manual Fan Speed Override options; On/Off, 2-Speed, 3-Speed or 6-Speed.

Once activated the user can override the Fan Speed by touching the Fan Icon on the screen. The desired speed can be set by touching multiple times on the screen. When Manual override is active 'M' is displayed above the coloured speed bar.

In ECO mode Manual Override is active. In OFF mode manual override is disabled.

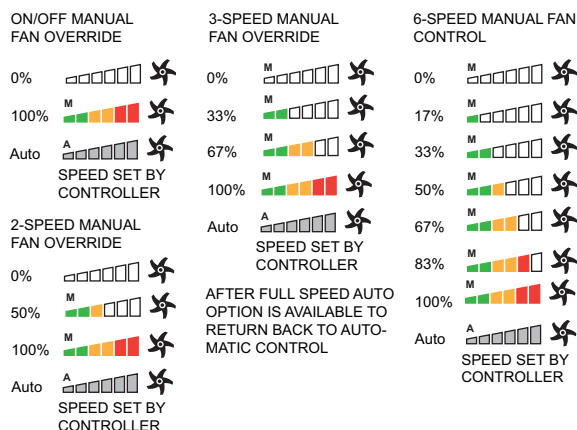

NOTE: Manual Fan Override sets the Fan Speed to defined values as described above and the Min. Fan Level parameter is ignored.

Auxiliary Heating Control Loop

The TRC-P series controllers have an auxiliary heating temperature control loop. The auxiliary control loop provides additional PI-control function for applications where second control loop is required e.g. second zone temperature control for bathrooms. The auxiliary control loop is activated by selecting Aux control for RI1 or RI2 input.

Note: RI2 is not available with TRC-P-2A3R.

CO2 Sensor Control Loop Operation (TRC-x-CO2 Models)

The CO2 models can measure and control the CO2 level. This can then be used in demand based control applications. The CO2 control output can then be configured to linked to any of the physical control outputs Y1, Y2 or Y3, or used in maximum demand control (MAX VAV, MAX FAN options)

The CO2 control loop output corresponds to the CO2 setpoint and the CO2 proportional band. If configured as Direct Control (typical), then if the CO2 level increases above the setpoint the loop output starts to modulate to 100%. When the CO2 level is the amount of the Proportional Band above the setpoint, the loop output is 100%. The configuration is done via the configuration parameters. The CO2 control loop can also be configured to operate as

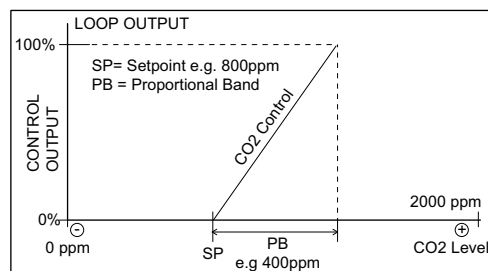

Proportional + Integral control by changing the Integral Action Time from 0 to a required value. The actuator direction can be changed via Output Direction parameter (Direct, Reverse).

In the OFF mode the CO2 loop output is set to 0%. In the ECO mode the CO2 loop operates as in the day mode.

VAV Maximum Demand

Each of the analogue outputs can also be configured as "Maximum VAV Demand". In this case the corresponding output (Y1, Y2, Y3) takes the maximum of the CO2 Loop and Cooling Temperature Loop demand output. This is typically used in demand based ventilation (VAV) to control fresh air damper when there is either demand for more fresh air, or demand for temperature cooling (typically fresh air cools down the room space).

Maximum Fan Demand

Each of the analogue outputs can be configured as "Maximum Fan Demand". In this configuration the corresponding output (Y1, Y2, Y3) takes the maximum demand of the CO2 Control Loop and Fan Speed Control Loop. This can provide fan speed boost at high CO2 level and when the fan speed temperature loop has increased the demand.

Humidity Control Loop Operation (-RH option)

The RH models can measure and control the relative humidity level. This can then be used in demand based control applications to increase the fresh air supply e.g. in the high humidity conditions. The control loop has both de-humidification and humidification outputs that can be linked to any of the physical control outputs Y1, Y2, or Y3. The direction of the both outputs can also be reversed to driver the actuators 100-0% instead of 0-100%.

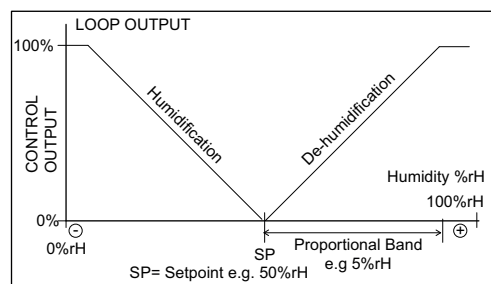

Cleaning Mode

After entering FURTHER INFORMATION screen, by selecting the CLEANING icon, it is possible to activate the cleaning mode. The TRC will enter a "Clean Screen" state where all touchscreen presses are ignored and 30 second countdown timer is displayed. This allows cleaning of the device itself.

Lock Mode

After entering FURTHER INFORMATION screen, by selecting the LOCK icon it is possible to lock the device. Now by entering the LOCK CODE, the device lock state can be activated.

The lock mode can be configured to work in different ways as described at the below table.

- DISABLED: Lock Mode Icon Not Available
- ON/OFF ONLY: Allows Mode Buttons Only
- ADJUST ONLY: Allows Temperature Adjustment Only
- NO INPUT: All Buttons Locked

If the lock code is set to 0000 (default), there is no need to enter the lock code and the lock entry screen is bypassed.

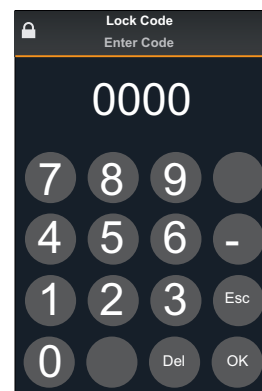

Lock Mode Options	Icon Active / Visible				
	Lock	Up and Down	OFF	Fan Speed	Mode Buttons
DISABLED	NO	YES	YES	YES	YES
ON/OFF ONLY	YES	NO	YES	NO	YES
ADJUST ONLY	YES	YES	NO	NO	NO
NO INPUT	YES	NO	NO	NO	NO

Remote Sensor RI1 and RI2 Inputs

A remote NTC10k3 sensor can be connected to the RI1 and RI2 inputs to be used for different control and display purposes. The options are:-

- DISABLED; the measurement is disabled
- ROOM; the input is used for the main temperature control loop
- FLOOR; the input is used for High/Low Limit Control
- OUTSIDE; the input is used to show the Outside Temperature
- NETWORK NTC10; the resistive input is available over the communication network as temperature.
- NETWORK 0-10V; the input is used as 0..10V network monitoring input (requires AI option)
- CO2; the input is used as CO2 0..10Vdc measurement for CO2 control (requires AI option)
- MAIN LOOP; the 0..10Vdc voltage is used for the main temperature control (requires AI option)

- CLOSE FOR ECO; the input operates as volt-free input to override to ECO mode when closed
- OPEN FOR ECO; the input operates as volt-free input to override to ECO mode when open
- CLOSE FOR OFF; the input operates as volt-free input to override to OFF mode when closed
- OPEN FOR OFF; the input operates as volt-free input to override to OFF mode when open

ROOM allows remote temperature sensor to be used for the main temperature loop control. The internal temperature sensor is disengaged from control.

FLOOR option links the temperature measurement to the High/Low Limit control. When the Floor Control is selected for RI1/RI2, the touchscreen SMALL ACTION CIRCLE starts to display the Floor Temperature (configurable). Note if both RI1/RI2 set to Floor Control RI1 takes precedence.

OUTSIDE allows outside (or network) temperature to be displayed on the screen. When the Outside is selected for RI1/RI2, the touchscreen SMALL ACTION CIRCLE starts to display the Outside Temperature (configurable). Note if both RI1/RI2 set to Outside RI1 takes precedence

NETWORK NTC10 option makes the NCT10 measurement available as temperature over the network.

Digital Input Modes

"CLOSE FOR" Configuration - The resistive input can be used as digital volt-free contact can be linked to e.g. external timer to switch the device to OFF mode during the timed period. When the device sees transition from open (COMFORT) to close (ECO/OFF MODE), the operating mode does not change until the Delay Timer has expired.

"OPEN FOR" Configuration - The resistive input can be used as digital volt-free input to activate ECO or OFF mode when the contact opens. In this mode it can be connected to a window switch, door card switch or PIR sensor. When the device sees transition from closed to open, the operating mode does not change until the countdown timer has expired (DIGITAL INPUT DELAY setting).

Note: Resistive Inputs as a Digital Input operate with approx. ten seconds delay and are not instantaneous. Therefore they are not suitable for fast switching (transition will be missed during the inherent delay time).

Note: RI2 is not available with TRC-P-2A3R.

If the TRC-P unit has been ordered with AI option, then inputs RI1 and RI2 become 0..10Vdc inputs.

NETWORK 0-10V; this selection allows the 0..10Vdc measurement to be converted to 0..100% and the measurement can be monitored over the network.

CO2; this selection converts the 0..10Vdc input to 0..2,000ppm. The measurement is available over the network for monitoring, and the measurement is automatically linked to the CO2 control.

MAIN LOOP; this selection converts the 0..10Vdc input to 0..50°C. The measurement is available over the network for monitoring, and the measurement is automatically linked to the main temperature control loop.

Note: RI2(AI2) is not available with TRC-P-2A3R.

The digital volt-free contact can be configured to the following options are:-

- CLOSE FOR ECO; Default
- OPEN FOR ECO
- CLOSE FOR OFF
- OPEN FOR OFF
- CHANGEOVER; changes stage 1 control between heating and cooling
- DISABLE COOLING; disabling the cooling stages when ON (condensation)
- CONTACT ALARM
- NETWORK
- CLOSE FOR BOOST (with CE-option only)
- OPEN FOR BOOST (with CE-option only)

"OPEN FOR" Configuration - The digital volt-free input can be used to activate ECO or OFF mode when the contact opens. In this mode it can be connected to a window switch, door card switch or PIR sensor. When the device sees transition from closed to open, the operating mode does not change until the countdown timer has expired (DIGITAL INPUT DELAY setting).

"CLOSE FOR" Configuration - The digital volt-free contact can be linked to e.g. external timer to switch the device to OFF mode during the timed period. When the device sees transition from open (COMFORT) to close (ECO/OFF MODE), the operating mode does not change until the Delay Timer has expired.

CHANGE-OVER - The digital input can also be used to override from heating to cooling mode. The device works in the heating mode when the contact is open, and in the cooling mode when the contact is closed.

CONDENSATION - when the digital input is closed the cooling loops are set to 0% to prevent condensation happening. In this mode digital input is typically connected to a condensation sensor.

2 x 0..10Vdc Input (AI Options)

DI Digital Input

CONTACT ALARM - when the contact closes the "DI Contact Alarm" alarm message is displayed on the screen.

NETWORK; the digital input is used for network monitoring purposes.

CLOSE/OPEN FOR BOOST - when digital input activates the controller operates in Boost mode, until the digital input de-activates (only with CE-option). With the digital input boost the 'Target' text is replaced by 'Boost' text.

Note: Digital Input Delay Timer parameter applies to all settings.

Analogue Outputs

The controller has three analogue 0-10Vdc outputs that are typically linked to the control loop outputs. The following list states the possible options:

- NETWORK; As a network 0-10Vdc output variable
- HEATING STAGE 1; 0-10Vdc output is linked to Heating Stage 1
- HEATING STAGE 2; 0-10Vdc output is linked to Heating Stage 2
- COOLING STAGE 1; 0-10Vdc output is linked to Cooling Stage 1
- COOLING STAGE 2; 0-10Vdc output is linked to Cooling Stage 2
- EC FAN; 0-10Vdc output is linked to Fan Control Loop Output
- CO2; 0-10Vdc output is linked to CO2 Control Loop Output (CO2 Models)
- MAXIMUM VAV; 0-10Vdc linked to maximum of the Cooling stage 1 and CO2 loops
- MAXIMUM FAN; 0-10Vdc linked to maximum of the CO2 loop and fan loop
- HUMIDIFICATION; 0-10Vdc output is linked to Humidity Control Loop Output (RH Models)
- DE-HUMIDIFICATION; 0-10Vdc output is linked to De-Humidity Control Loop Output (RH Models)
- AMBER/RED; 0-10dc is @ 50% when Amber or Red alarm is active
- RED; 0-10Vdc is @ 100% when Red alarm is active
- HEATING STAGE 1 STAT; see RELAY OUTPUT / ON-OFF control chapter
- COOLING STAGE 1 STAT; see RELAY OUTPUT / ON-OFF control chapter
- FAN STAT; see RELAY OUTPUT / ON-OFF control chapter
- AUX LOOP; see AUXILIARY HEATING CONTROL LOOP chapter
- 6-PORT; see 6-PORT VALVE control chapter
- 6-PORT REVERSE; see 6-PORT VALVE control chapter (reverse operation)

Analogue Output Scaling / Output Limitation

Each of the analogue outputs (Y1,Y2,Y3) can have

- Output minimum voltage (percentage)
- Output maximum voltage (percentage)

The connected control loop output 0..100% is then scaled from minimum voltage to maximum voltage.

For example in the EC fan control, if the fan is required to run always at minimum level, the minimum control output voltage can set to 10% (1V) and the maximum output 70% (7V). In this case the control loop output 0..100% is scaled to be 10..70% at the analogue output. This allows maximum noise levels to be limited and the fan to have a minimum fan speed.

The values are available via the communication network from network master read/write.

Relay Outputs / Fan Speed Control (TRC-P-2A3R/TRC-P-1A4R/TRC-P-H-3R2T)

TRC-P-(H)-2A3R, TRC-P-1A4R and TRC-P-H-3R2T have 3 relay outputs that be used to control 3-speed fans. The relay 1 is switched ON approx. 30% of fan demand, relay 2 is switched ON at approx. 60% of fan demand and relay 3 is switched ON approx 90% of fan demand. Only one relay is on at any given time. The relays are switched OFF approx 20% below the fan switch ON level.

NOTE:For the fan relay outputs to operate, the Y1 (Analogue Output Y1 Mode) has be set to 'Modulating Fan' (default setting).

NOTE:TRC-P-H-2A3R/H-3R2T relays are rated 7A resistive. TRC-P-2A3R/1A4R relays are rated 0.5A resistive.

Relay Output / On-Off Control (TRC-P-1A4R)

TRC-P-1A4R have 4th 230Vac relay that can be used to switch 230Vac On/Off. The output can be used to switch heating valves, cooling valves or plant enable outputs.This is done by configuring the output Y2 setting to one of the dollowing settings:-

HEATING STAGE 1 STAT; thermostatic switching of output, 100% (TRC-P-1A4R RLY4 via Y2 ON) when Heating1 Stage at 10% or over, switches back to 0% (TRC-P-1A4R RLY4 via Y2 OFF) when Heating1 Stage output 0%

COOLING STAGE 1 STAT; thermostatic switching of output, 100% (TRC-P-1A4R RLY4 via Y2 ON) when Cooling1 Stage at 10% or over, switches back to 0% (TRC-P-1A4R RLY4 via Y2 OFF) when Cooling1 Stage output 0%

FAN STAT; thermostatic switching of output, 100% (TRC-P-1A4R RLY4 via Y2 ON) when Fan Loop at 10% or over, switches back to 0% (TRC-P-1A4R RLY4 via Y2 OFF) when Fan Loop output 0%

As default for TRC-P-1A4R the Y2 has been configured as 'HEATING STAGE1 STAT'.

NOTE: With TRC-P-1A4R you can also configure Y1 to 'HEATING1 or COOLING1 STAT'. With this configuration RELAY3 becomes also as ON/OFF valve output. Therefore the TRC-P-1A4R

controller can control both heating and cooling ON/OFF valves (and EC Fan via 0-10Vdc output).

PWM Control / Digital Outputs (TRC-P-1A2T/TRC-P-H-3R2T)

The TRC-P-1A2T/TRC-P-H-3R2T controller has two digital triac outputs. The digital outputs are used for PWM control for heating and cooling valves. The PWM period is set in the INPUTS/OUTPUTS PWM Period Setting. The below diagram illustrates the principle of the PWM control..

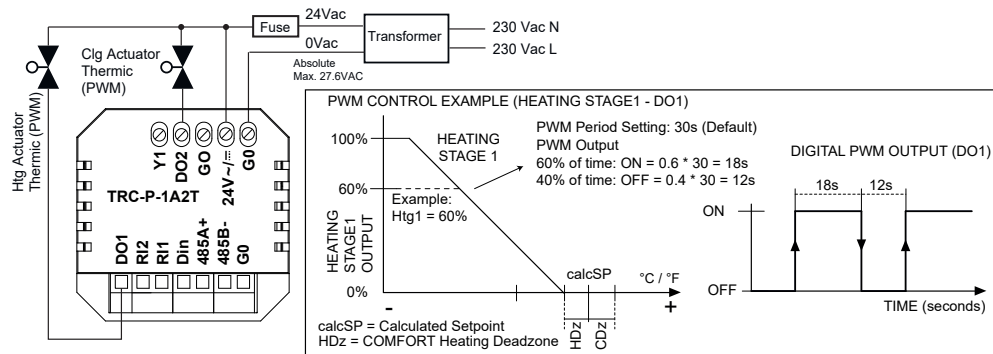

NOTE:With TRC-P-1A4R/3R2T analogue outputs Y2 & Y3 are not available. Y1 is available for EC Fan control (or other valid output control - see Y1 options). With TRC-P-H-3R2T the Y1 is set as default 'Modulating Fan', and the device does not have 0-10Vdc outputs.

NOTE:Please note that DO1 and DO2 are 24Vac Triacs switching to 0V. Please follow the above wiring diagram.

Belimo 6-Port Control Mode

The TRC-P controller can be configured to control Belimo 6-Port valve by selecting **6-Port** or **6-Port Reverse** mode for the analogue output (Y1/Y2/Y3). The diagram below illustrates the operation.

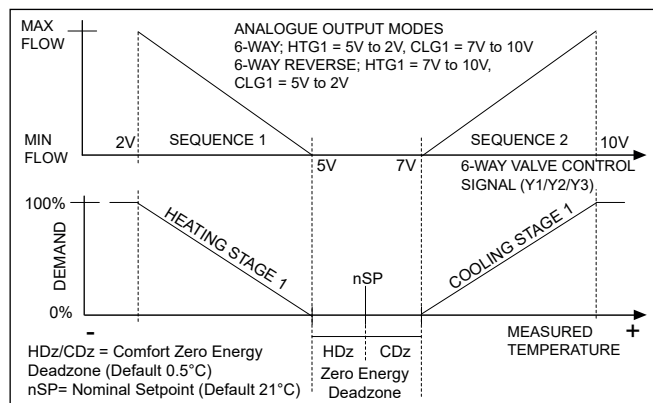

Note: Analogue Output Scaling/Anti-JAM is not available in the 6-Port and 6-Port Reverse modes. Number of Heating and Cooling Stages must be set at minimum to one.

AntiJAM Valve Exercise Function

If the AntiJAM function is enabled the controller monitors for inactivity. If the control outputs have been fully closed or fully open more than the AntiJAM period, the controller will open/close the outputs to by 30% for a short period of time. The AntiJAM function is enabled through the configuration parameters by selecting the required AntiJAM period by days.

Alarm Display

The TRC-P controller provides two Alarm Modules each of which can be configured to detect and display alarm condition on either CO2, Humidity or Temperature Sensor (internal or external depending on which is being used). The alarm function can be disabled by setting the alarm source as "NONE". Alarms are disabled by default.

Each Alarm has three alarm states – No Alarm, Amber and Red. When in alarm the alarm is displayed by alarm bell in ACTION CIRCLE. The ACTION CIRCLE rotates all active measurements so the alarm is displayed when the corresponding measurement is displayed.

HIGH LIMIT ALARM

If the Red threshold is set higher than the amber threshold:



If Sensor >=Amber Threshold; Alarm = Amber

If Sensor >= Red Threshold; Alarm = Red

Hysteresis acts to prevent a return to a lower alarm level until the Sensor value falls to a Threshold - Hysteresis

LOW LIMIT ALARM

If the Amber threshold is set higher than the Red Threshold then:

If Sensor <= Amber Threshold; = Amber

If Sensor <= Red Threshold; Alarm = Red

Hysteresis acts to prevent a return to a lower alarm level until the Sensor value rises to a Threshold + Hysteresis.

Sensor Fault Display

When entering FURTHER INFORMATION AND SETTINGS screen and a sensor/input fault is active, select the fault icon for more information.

The typical alarm reasons are:

- External sensor 1 (Res1) fault (when activated; out of range)
- External sensor 2 (Res1) fault (when activated; out of range)
- Built-in sensor fault
- Digital Input Alarm

FURTHER SETTINGS AND INFORMATION

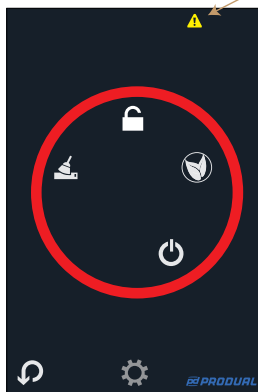

SELECT FAULT ICON FOR MORE INFORMATION

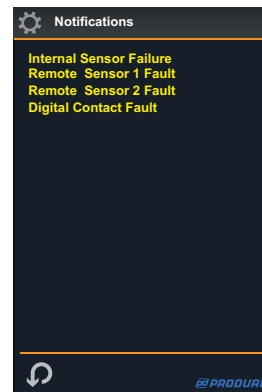

Controller Status Information Display

After entering CONFIGURATION PARAMETER GROUP screen and selecting the INFO icon it is possible to see the current status information of the controller. The page shows the current measurement and output information.

LIVE INFORMATION SCREEN

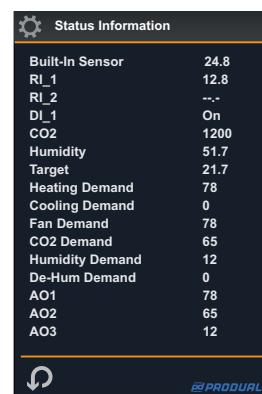
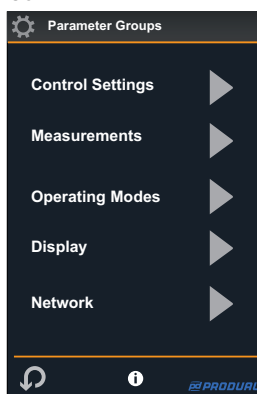

SELECT INFO ICON FOR

Configuration Parameters

ENTER MAINTENANCE CODE FOR MAINTENANCE MODE

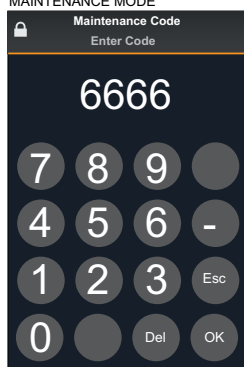

CLICK TO ACCESS SETTINGS GROUP

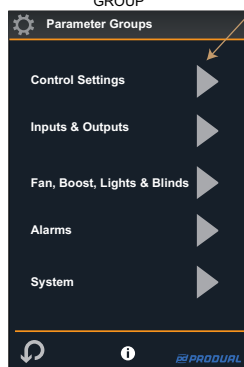

CLICK TO CHANGE SETTING



ACCESS MORE SETTINGS

The TRC-P devices are configured to operate in different modes via the configuration parameters accessible through the maintenance mode.

To enter the maintenance mode click the COG WHEEL icon in the FURTHER SETTINGS SCREEN and enter the maintenance mode password (default 6666).

NOTE:The maintenance mode password can be changed in the configuration settings. Make sure that you note the new password if changed. If the Maintenance Code is set as 0000, the Maintenance Code entry screen is bypassed (i.e. no protection).

NOTE:It is good practice to reset the device after the configuration has been completed. Soft reset is automatically carried out after entering and exiting System configuration menu, or alternative power cycle the device.

CONTROL SETTINGS		
Parameter Name	Description	Range
Nominal SP	Nominal Setpoint (Temperature Control)	0.0...95.0°C/°F (Default 21.0°C)
Heating DZ COMFORT	Heating Deadzone in COMFORT mode	0.0...25.0°C/°F (Default 0.5°C)
Cooling DZ COMFORT	Cooling Deadzone in COMFORT mode	0.0...25.0°C/°F (Default 0.5°C)
Heating DZ ECO	Heating Deadzone in ECO Mode	0.0...25.0°C/°F (Default 4.0°C)
Cooling DZ ECO	Cooling Deadzone in ECO Mode	0.0...25.0°C/°F (Default 4.0°C)
Frost SP	Night Frost Setpoint (OFF Mode)	0.0...95.0°C/°F (Default 8.0°C)
Setpoint Adj. Max.	Temperature Setpoint Maximum Adjustment	0.0...20°C/°F (Default 3.0)
Setpoint Adj. Min.	Temperature Setpoint Minimum Adjustment	-20.0...0°C/°F (Default -3.0)
PB	Temperature Control Proportional Band	1.0..50.0 °C/°F (Default 4.0)
IA	Integral Action time of the temperature control loop. Set to 0 to disable.	0..1,200 seconds (Default 600s)
Heating Stages	Number of Heating Stages	0 = None 1 = 1-Stage (Default) 2 = 2-Stages
Heating Stage 1 Dir.	Heating Stage 1 Direction	0 = Reverse (Default) 1 = Direct
Heating Stage 2 Dir.	Heating Stage 2 Direction	0 = Reverse (Default) 1 = Direct
Cooling Stages	Number of Cooling Stages	0 = None 1 = 1-Stage (Default) 2 = 2-Stages
Cooling Stage 1 Dir.	Cooling Stage 1 Direction	0 = Reverse 1 = Direct (Default)
Cooling Stage 2 Dir.	Cooling Stage 2 Direction	0 = Reverse 1 = Direct (Default)
Aux. SP	Auxiliary Heating Control Loop Setpoint	0.0...95.0°C/°F (Default 21.0°C)
Aux. PB	Auxiliary Heating Control Loop Proportional Band	1.0..50.0 °C/°F (Default 4.0)
Aux. IA	Auxiliary Heating Control Loop Integral Action	0..1,200 seconds (Default 600s)
Aux Dir.	Auxiliary Control Loop Actuator Direction (actuator direction, Direct = 0..100%, Reverse = 100..0%)	0 = Reverse Acting 1 = Direct (Default)
CO2 SP	CO2 Setpoint	0..5000ppm (Default 1,000 ppm)
CO2 PB	CO2 Proportional Band	10..5000 ppm (Default = 300 ppm)
CO2 IA	Integral Action time of the CO2 control loop. Set to 0 to disable.	0..10,000 seconds (Default 0)
Humidity SP	Humidity Setpoint	0.0...100.0 %rH (Default 50%)
Humidity PB	Humidity Proportional Band	0.1...100.0 %rH (Default 20.0%)
Humidity IA	Integral Action time of the humidity control loop. Set to 0 to disable.	0..10,000 seconds (Default 0)
Limit High	High Limit Setpoint; High Limit Control	0.0..95.0°C/°F (Default 35.0°C)
Limit Low	Low Limit Setpoint; Low Limit Control	0.0..95.0°C/°F (Default 16.0°C)
Limit Ratio	Low/High Limit Ratio Note: 0.0 setting disables the reset control.	0.0..5.0 (0.0=Disabled, Default)
Changeover Low	Low Limit where the TRC Automatically Switches to Cooling Mode (Cold water supplied)	0.0..95.0°C/°F (Default 20.0°C)
Changeover High	High Limit where the TRC Automatically Switches to Heating Mode (Hot water supplied)	0.0..95.0°C/°F (Default 25.0°C)

INPUTS & OUTPUTS		
Parameter Name	Description	Range
Room Sensor Text	Description for the Room Sensor (Built-In Sensor / RI1/RI2)	1 = Room (Default) 2 = Floor 3 = Outside 4 = Zone 1 5 = Zone 2 6 = Zone 3 7 = Bathroom 8 = Sauna 9 = Bedroom 10 = Kitchen 11 = Cooler 12 = Flow 13 = Hot Water 14 = Tank 15 = Pool 16 = Cabin
Floor Sensor Text	Description for the Floor Sensor (RI1/RI2) Default; 2 = Floor Note: Disabled removes Floor Sensor Text and Measurement from Display. The device may require Soft Reset after setting 'Disabled'. This is done by entering and exiting the System configuration menu.	0 = Disabled 1 = Room 2 = Floor 3 = Outside 4 = Zone 1 5 = Zone 2 6 = Zone 3 7 = Bathroom 8 = Sauna 9 = Bedroom 10 = Kitchen 11 = Cooler 12 = Flow 13 = Hot Water 14 = Tank 15 = Pool 16 = Cabin
Aux. Sensor Text	Description for the Aux Sensor (RI1 / RI2 / Network Value) Default; 3 = Outside Note: Disabled removes Aux Sensor Text and Measurement from Display. The device may require Soft Reset after setting 'Disabled'. This is done by entering and exiting the System configuration menu.	0 = Disabled 1 = Room 2 = Floor 3 = Outside 4 = Zone 1 5 = Zone 2 6 = Zone 3 7 = Bathroom 8 = Sauna 9 = Bedroom 10 = Kitchen 11 = Cooler 12 = Flow 13 = Hot Water 14 = Tank 15 = Pool 16 = Cabin
Humidity Display	Enable / Disable Humidity Display (if option fitted)	0 = Disabled 1 = Enabled (default)
Digital Input Mode	Digital Input Operation	0 = Close for ECO (Default) 1 = Open for ECO 2 = Close for OFF 3 = Open for OFF 4 = Heating/Cooling Change-Over 5 = Disable Cooling 6 = Contact Alarm 7 = Network Measurement 8 = Close for BOOST 9 = Open for BOOST
Digital Input Delay	Digital Input Delay Timer (transition from active to non-active)	0..28,800 seconds (Default 0s)
RI1 Mode	Resistive Input 1 Mode	0 = Disabled (default) 1 = Room (NTC10 Temp Control) 2 = Floor (NTC10 Floor Low/High Limit Control) 3 = Aux. Loop 4 = Network NTC10 5 = Network 0-10V 6 = CO2; 0..2000ppm = 0-10V (AI-option) 7 = Main Loop (Control Temp; 0..50°C = 0-10V; AI-option) 8 = Close for ECO (DI-mode) 9 = Open for ECO (DI-mode) 10 = Close for OFF (DI-mode) 11 = Open for OFF (DI-mode)
RI2 Mode	Resistive Input 2 Mode	
Aux. Loop Source	Source for the Auxiliary Loop Sensor (Display activated when valid temperature is sent)	0 = Built-In Sensor 1 = Network Temp
Internal Sensor Cal.	Internal Sensor One Point Compensation	-10.0..+10.0 °C/°F
RI1 Cal.	Sensor Connected to RI1 Calibration	-10.0..+10.0 °C/°F
RI2 Cal.	Sensor Connected to RI1 Calibration	-10.0..+10.0 °C/°F
CO2 Cal.	CO2 Sensor Calibration (CO2 Models)	-500...+500 ppm

INPUTS & OUTPUTS		
Parameter Name	Description	Range
Humidity Cal.	Humidity Calibration (RH Models)	-10.0..+10.0 % rH
Y1	Analogue Output Y1 Mode Default: Modulating Fan NOTE: With TRC-P-2A3R, 1A4R and 3R2T do not change this setting - leave to default.	0 = Network Value 1 = Heating Stage 1 2 = Heating Stage 2 3 = Cooling Stage 1 4 = Cooling Stage 2
Y2	Analogue Output Y2 Mode Default: Heating Stage 1 TRC-P-1A4R Default: Heating Stat1 NOTE: Not available with TRC-P-1A2T/3R2T.	5 = Modulating Fan (EC) 6 = CO2 Control 7 = Maximum VAV 8 = Maximum Fan 9 = Humidification
Y3	Analogue Output Y3 Mode Default: Cooling Stage. NOTE: Not available with TRC-P-1A2T/3R2T.	10 = De-humidification 11 = Amber / Red 12 = Red 13 = Heating Stage1 Sta 14 = Cooling Stage1 Stat 15 = Fan Stat 16 = Aux Loop 17 = 6-Port (Valve) 18 = 6-Port Reverse (Valve)
Y1 Min.	Analogue Output Y1 Minimum Value	0..100%(0% = default)
Y1 Max.	Analogue Output Y1 Minimum Value	0..100% (100% = default)
Y2 Min.	Analogue Output Y2 Minimum Value	0..100%(0% = default)
Y2 Max.	Analogue Output Y2 Minimum Value	0..100% (100% = default)
Y3 Min.	Analogue Output Y3 Minimum Value	0..100%(0% = default)
Y3 Max.	Analogue Output Y3 Minimum Value	0..100% (100% = default)
Anti-JAM	Valve Exercise	0..14 Days (default 0 = disabled)
PWM Period	PWM Period (TRC-P-1A2T/TRC-H-3R2T)	0..120 Seconds (default 30)

FAN, BOOST, TIMES		
Parameter Name	Description	Range
Fan Speed Display	Selecting the Fan Speed (User Adjustment) for the Display Note: Modes 2,3,4 set the number of steps the user can manually adjust the fan speed.	0 = None (Default) 1 = No Input (no user adj.) 2 = 0 - 1 (0%, 100%) 3 = 0 - 1 - 2 (0%, 50%, 100%) 4 = 0 - 1 - 2 - 3 (0%, 33%, 66%,100%) 5 = 0 - 1 - 2 - 3 - 4 - 5 - 6
Fan Speed Source	Fan Speed Control Source (The fan speed follows theselected control loop output. The minimi Fan Level parameter applies in operation)	0 = Heating 1 and Cooling 1 Stage (Default) 1 = Heating Stage1 2 = Cooling Stage 1 3 = Heating and Cooling Stage 2 4 = Heating Stage 2 5 = Cooling Stage 2 6 = CO2 7 = Humidification 8 = De-Humidification 9 = Maximum VAV (Cooling/CO2) 10 = Maximum Temp/Hum 11 = Aux. Loop
Min Fan Level	Fan Speed Minimum Active Level	0..100% (Default 0%)
Fan Off Delay	Fan Switch Off Delay when Fan Speed Source Demand < Min Fan Level. Note: Only active if Min Fan Level is set.	0..28,800 seconds (Default = 0) 0 = Infinite
Boost Time	Boost Mode Running Time	0 = Permanent 1..480 minutes (Default 0)
Boost Target	Boost Button Target Operation	0 = Nominal SP (Temperature) 1 = CO2 SP 2 = Humidity SP 3 = Dehum SP 4 = Fan Demand 5 = Aux. Temp SP
Boost Setpoint Value	Boost Setpoint Value, The target value that the boost button affects (whole integers).	0..5000 (default 25)

FAN, BOOST, TIMES		
Parameter Name	Description	Range
Mode Button	COMFORT / ECO / OFF / BOOST Button Mode Operation Mode	0 = Active (Default) 1 = Indication Only

ALARMS		
Parameter Name	Description	Range
Alarm 1 Source	Source for the Alarm Display	0 = CO2 Sensor 1 = Room (Temperature) 2 = Humidity 3 = None (Default)
Alarm 1 Amber Threshold	Alarm 1 Amber Backlight Switching Point	0..5000 (Default 0)
Alarm 1 Red Threshold	Alarm 1 Amber Backlight Switching Point	0..5000 (Default 0)
Alarm 1 Hysteresis	Hysteresis for Alarm 1	0..5000 (Default 0)
Alarm 2 Source	Source for the Alarm Display	0 = CO2 Sensor 1 = Room (Temperature) 2 = Humidity 3 = None (Default)
Alarm 2 Amber Threshold	Alarm 2 Amber Backlight Switching Point	0..5000 (Default 0)
Alarm 2 Red Threshold	Alarm 2 Amber Backlight Switching Point	0..5000 (Default 0)
Alarm 2 Hysteresis	Hysteresis for Alarm 2	0..5000 (Default 0)

SYSTEM		
Parameter Name	Description	Range
Address	Modbus Address (Only Modbus versions) BACnet MAC Address (Only BACnet versions)	0..247 (Default 1) 0..127 (Default 1)
Baud Rate (Only Modbus/BACnet versions)	Modbus / BACnet Baud Rate	0 = 9600 (Default) 1 = 19200 2 = 38400 3 = 57600 4 = 76800
Parity (Only Modbus/BACnet versions)	Parity	0 = None (Default) 1 = Odd 2 = Even
Stop Bits (Only Modbus/BACnet versions)	Stop Bits	0 = 1 Stop Bit (Default) 1 = 2 Stop Bits
Device ID (Only BACnet versions)	BACnet Device ID	0..4,194,303 (Default Auto=651001)
Service Pin (Only BACnet versions)	Bacnet Service Pin (when activated the device sends BACnet I-AM message)	0 = Disabled (default) 1 = Enabled
Brightness	Backlight Brightness	0..20 (default 5)
Show Unit Swap	Shows the Fahrenheit / Celcius Unit Selection Button	0 = Disabled (default) 1 = Enabled
Lock Mode	Lock Operation	0 = Disabled (default) 1 = On /Off Only (Lights & Blinds) 2 = Temp Adjust Only Available 3 = No Input - All Buttons Disabled
Lock Code	Lock Mode Password	0000 - 9999 (default 0000)
Maintenance Code	Maintenance Mode Password	0000 - 9999 (default 6666)
Staff Code	Staff Page Password - Access Password to Further Settings Screen	0000 - 9999 (default 0000 = disabled)
Language	Language	EN = English (Default) FR = French
Native Units (Defaults)	Selects either Fahrenheit / Celsius as Native Units NOTE: RELOADS DEFAULTS	C = Celsius (default) F = Fahrenheit
Auto Daylight Savings	Automatic Summer/Winter Time Adjustment	0 = Disabled (default) 1 = Enabled
Screen Cycle Speed	Cycle Speed of Measurements in the ACTION RING Fast = 4.3 secs, Medium = 7.8 secs, Slow = 10.8 secs	0 = Fast 1 = Medium (default) 2 = Slow
Screen Refresh Rate	Refresh Rate of the LCD Screen	0 = Fast (default) 1 = Medium 2 = Slow

SYSTEM		
Parameter Name	Description	Range
Reload Default	Reload Default Settings	0 = Off (default) 1 = On
Version	Software Version	x.xx (BACnet/Modbus)

Parameter Storage

The configuration parameters are stored in the non-volatile memory. When the changes are carried out via the display, the parameters are stored in the non-volatile memory when the controller returns to a normal display mode. If the changes are carried out over the network (Modbus or BACnet), then "NonVol Update" register/object is required to be forced on to save the changes. The register will automatically return to normal state

Modbus Registers

The controller supports the following Modbus registers and function codes. The default communication speed is 9600 bps, 8 data bits, Parity None and 1 Stop Bit. The default Modbus Slave address is 1. The device Parity can be changed between Odd, None and Even. The baud rate is selectable between 9600, 19200, 38400, 57600 and 76800 bps. The table shows the register offsets starting from 0 (0 Base) register address. For example, the Temperature is read from Modbus register 0 using Function Code 04. Some Modbus masters will require one to be added to Modbus registers (i.e. 1 Base). In this case Function Code 04, register 101 needs to be entered.

Register	Parameter Description	Data Type	Raw Data	Range
	FUNCTION CODE 01 - READ COILS FUNCTION CODE 05 - WRITE SINGLE COIL FUNCTION CODE 15 - WRITE MULTIPLE COILS			
100	OFF Mode Override		0..1	Off - On
101	ECO Mode Override		0..1	Off - On
102	Heating/Cooling Mode (change-over mode)		0..1	0 = Heating, 1 = Cooling
	FUNCTION CODE 02 - READ DISCRETE INPUTS (Add 10,000 for Modicon Addressing)			
100	Digital Input Status (DI1)		0..1	Off - On
101	Boost Status		0..1	Off - On
102	Screen Lock Status		0..1	Off - On
103	Digital Output 1 (TRC-P-1A2T)		0..1	Off - On
104	Digital Output 2 (TRC-P-1A2T)		0..1	Off - On
	FUNCTION CODE 04 - READ INPUT REGISTERS (Add 30,000 for Modicon Addressing)			
100	Built-In Temperature Measurement	Signed 16	-400...3020	-40.0...150.0°C (-40.0...302.0°F)
101	Remote Sensor 1 Measurement (Resistive Input 1)	Signed 16	-400...3020	-40.0...150.0°C (-40.0...302.0°F)
102	Remote Sensor 2 Measurement (Resistive Input 2)	Signed 16	-400...3020	-40.0...150.0°C (-40.0...302.0°F)
103	Current Calculated Setpoint	Signed 16	-400...3020	-40.0...150.0°C (-40.0...302.0°F)
104	Device Current Mode	Unsigned 16	0..3	0 = Comfort 1 = ECO 2 = OFF 3 = Boost
105	Relative Humidity Measurement	Unsigned 16	0..1000	0..100.0 %rH
106	CO2 Measurement	Unsigned 16	0..5000	0..5,000 ppm
107	Analogue Output Y1	Unsigned 16	0..1000	0..100.0 %
108	Analogue Output Y2	Unsigned 16	0..1000	0..100.0 %
109	Analogue Output Y3	Unsigned 16	0..1000	0..100.0 %
110	Alarm 1 State	Unsigned 16	0..3	0 = Normal (No Alarm) 1 = Amber Alarm 2 = Red Alarm
111	Alarm 2 State	Unsigned 16	0..3	0 = Normal (No Alarm) 1 = Amber Alarm 2 = Red Alarm
114	Analogue Input 1 (RI1) Measurement (0-10V, Option)	Unsigned 16	0..1000	0..100.0 %
115	Analogue Input 2 (RI2) Measurement (0-10V, Option)	Unsigned 16	0..1000	0..100.0 %

Register	Parameter Description	Data Type	Raw Data	Range
116	Fan Speed Demand	Unsigned 16	0..1000	0..100.0 %
117	Thermic1 Demand	Unsigned 16	0..1000	0..100.0 %
118	Thermic2 Demand	Unsigned 16	0..1000	0..100.0 %
200	Firmware Versions	Unsigned 16	N/A	N/A
FUNCTION CODE 03 - READ HOLDING REGISTERS (For Modicon Addressing Add 40,000) FUNCTION CODE 06 - WRITE SINGLE HOLDING REGISTER FUNCTION CODE 16 - WRITE MULTIPLE HOLDING REGISTERS				
100	Nominal Setpoint	Unsigned 16	0...950	0.0...95.0°C/°F (Default 20°C)
101	Heating Comfort Deadzone	Unsigned 16	0...250	0.0...25.0°C/°F (Default 0.5°C)
102	Cooling Comfort Deadzone	Unsigned 16	0...250	0.0...25.0°C/°F (Default 0.5°C)
103	ECO Heating Deadzone	Unsigned 16	0...250	0.0...25.0°C/°F (Default 4.0°C)
104	ECO Cooling Deadzone	Unsigned 16	0...250	0.0...25.0°C/°F (Default 4.0°C)
105	Frost Setpoint	Unsigned 16	0...950	0.0...95.0°C/°F (Default 8°C)
106	Setpoint Adjust Minimum	Signed 16	-200..0	-20.0..0.0 °C/°F (Default -3.0)
107	Setpoint Adjust Maximum	Signed 16	0..200	0.0..20.0 °C/°F (Default 3.0)
108	Temperature Control Proportional Band	Unsigned 16	10...500	1.0...50.0°C/°F (Default 4°C)
109	Temperature Control Integral Action Time	Unsigned 16	0..1200	0..1200 seconds (600s default)
110	Number of Heating Stages	Unsigned 16	0..2	0 = None 1 = 1-Stage (Default) 2 = 2-Stages
111	Heating Stage 1 Direction	Unsigned 16	0..1	0 = Reverse (Default) 1 = Direct
112	Heating Stage 2 Direction	Unsigned 16	0..1	0 = Reverse (Default) 1 = Direct
113	Number of Cooling Stages	Unsigned 16	0..2	0 = None 1 = 1-Stage (Default) 2 = 2-Stages
114	Cooling Stage 1 Direction	Unsigned 16	0..1	0 = Reverse 1 = Direct (Default)
115	Cooling Stage 2 Direction	Unsigned 16	0..1	0 = Reverse 1 = Direct (Default)
116	High Limit Setpoint	Unsigned 16	0...950	0..95°C/°F (Default 35.0°C)
117	Low Limit Setpoint	Unsigned 16	0...950	0..95°C/°F (Default 16.0°C)
118	Limit Ratio	Unsigned 16	0..50	0.0..5.0 (0.0=Disabled, Default)
119	CO2 Control Setpoint	Unsigned 16	0..5,000	0..5000ppm (Default 1,000 ppm)
120	CO2 Proportional Band	Unsigned 16	10..5,000	10..5000 ppm (Default = 300 ppm)
121	CO2 Control Integral Action	Unsigned 16	0..10,000	0..10,000 seconds (Default 0)
122	CO2 Output Direction	Unsigned 16	0..1	0 = Reverse Acting 1 = Direct Acting (Default)
123	Humidity Control Setpoint	Unsigned 16	0..1000	0.0...100.0 %rH (Default 50%)
124	Humidity Proportional Band	Unsigned 16	10..1000	1.0...100.0 %rH (Default 20.0%)
125	Humidity Control Integral Action	Unsigned 16	0..10,000	0..10,000 seconds (Default 0)
126	Humidification Output Direction	Unsigned 16	0..1	0 = Reverse Acting 1 = Direct Acting (Default)
127	De-Humidification Output Direction	Unsigned 16	0..1	0 = Reverse Acting 1 = Direct Acting (Default)
128	Fan Speed Display	Unsigned 16	0..5	0 = No Display (Default) 1 = Display Only (no user adj.) 2 = 0 - 1 (0%, 100%) 3 = 0 - 1 - 2 (0%, 50%, 100%) 4 = 0 - 1 - 2 - 3 (0%, 33%, 66%, 100%) 5 = 0 - 1 - 2 - 3 - 4 - 5 - 6

Register	Parameter Description	Data Type	Raw Data	Range
129	Fan Speed Source	Unsigned 16	0..11	0 = Heating 1 and Cooling 1 Stage (Default) 1 = Heating Stage1 2 = Cooling Stage 1 3 = Heating and Cooling Stage 2 4 = Heating Stage 2 5 = Cooling Stage 2 6 = CO2 7 = Humidification 8 = De-Humidification 9 = Maximum VAV (Cooling/CO2) 10 = Maximum Temp/Hum 11 = Aux. Loop
130	Min Fan Level	Unsigned 16	0..100	0...100% (Default 0%)
131	Y1 Output Mode Default: Modulating Fan	Unsigned 16	0..18	0 = Network Value 1 = Heating Stage 1 2 = Heating Stage 2 3 = Cooling Stage 1 4 = Cooling Stage 2 5 = Modulating Fan (EC) 6 = CO2 Control 7 = Maximum VAV 8 = Maximum Fan 9 = Humidification 10 = De-humidification 11 = Amber / Red 12 = Red 13 = Heating1 Sta 14 = Cooling1 Stat 15 = Fan Stat 16 = Aux. Loop 17 = 6-Port (Valve) 18 = 6-Port Reverse (Valve)
132	Y2 Output Mode Default: Heating Stage 1 TRC-P-1A4R Default: Heating1 Stat	Unsigned 16	0..18	
133	Y3 Output Mode Default: Cooling Stage 1	Unsigned 16	0..18	
134	Analogue Output Y1 Override Value	Unsigned 16	0..1000	0..100% (0..10.0V) - Default 0
135	Analogue Output Y2 Override Value	Unsigned 16	0..1000	0..100% (0..10.0V) - Default 0
136	Analogue Output Y3 Override Value	Unsigned 16	0..1000	0..100% (0..10.0V) - Default 0
137	Y1 Minimum Output	Unsigned 16	0..1000	0...100.0 % (Default 0.0%)
138	Y1 Maximum Output	Unsigned 16	0..1000	0...100.0 % (Default 100.0%)
139	Y2 Minimum Output	Unsigned 16	0..1000	0...100.0 % (Default 0.0%)
140	Y2 Maximum Output	Unsigned 16	0..1000	0...100.0 % (Default 100.0%)
141	Y3 Minimum Output	Unsigned 16	0..1000	0...100.0 % (Default 0.0%)
142	Y3 Maximum Output	Unsigned 16	0..1000	0...100.0 % (Default 100.0%)
143	Anti-JAM Time-out	Unsigned 16	0..14	0..14 Days 0 = Disabled (Default)
144	RI1 Mode	Unsigned 16	0..11	0 = Disabled (default) 1 = Room (NTC10 Control) 2 = Floor (NTC10 High/Low Lim) 3 = Aux. Loop 4 = Network NTC10 5 = Network 0-10V 6 = CO2 0-10V (0..2000 =0-10V) 7 = Main Loop (0..50°C=0-10V) 8 = Close for ECO (DI-mode) 9 = Open for ECO (DI-mode) 10 = Close for OFF (DI-mode) 11 = Open for OFF (DI-mode)
145	RI2 Mode	Unsigned 16	0..11	
146	Outside Temperature Source	Unsigned 16	0..1	0 = Built-In Sensor (Default) 1 = Network Sensor
147	Outside Air Temperature Network Write Note: If Outside Temperature Source is set to 1, and a valid (within range) value is sent to this parameter the touchscreen starts to show Outside temperature in the SMALL ACTION CIRCLE.	Signed 16	-580...1220	-58.0... 122.0°C/°F (Default 0.0)

Register	Parameter Description	Data Type	Raw Data	Range
148	Digital Input Mode	Unsigned 16	0..9	0 = Close for ECO (Default) 1 = Open for ECO 2 = Close for OFF 3 = Open for OFF 4 = Heating/Cooling Change-Over 5 = Disable Cooling 6 = Contact Alarm 7 = Network Measurement 8 = Close for BOOST 9 = Open for BOOST
149	Digital Input Delay	Unsigned 16	0..28,800	0..28,800 seconds (Default 0s)
150	Internal Sensor Calibration	Signed 16	-100..+100	-10.0..+10.0 °C/°F
151	RI1 Calibration	Signed 16	-100..+100	-10.0..+10.0 °C/°F
152	RI2 Calibration	Signed 16	-100..+100	-10.0..+10.0 °C/°F
153	CO2 Calibration	Signed 16	-500..+500	-500...+500 ppm
154	Humidity Calibration	Signed 16	-100..+100	-10.0..+10.0 % rH
155	Lock Mode	Unsigned 16	0..4	0 = Lock mode disabled (default) 1 = On/Off workable only 2 = Temp settings only available 3 = All buttons disabled
156	Lock Mode Password	Unsigned 16	0..9999	0000...9999
157	Boost Time	Unsigned 16	0..480	0 = Permanent (Default 0) 1..480 minutes
158	Boost Target	Unsigned 16	0..5	0 = Nominal SP (Temperature) 1 = CO2 SP 2 = Humidity SP 3 = Dehum SP 4 = Fan Demand 5 = Aux. Temp SP
159	Boost Target Value	Unsigned 16	0..5000	0..5000 (default 25)
160	Mode Display Button	Unsigned 16	0..1	0 = Indication Only 1 = Active (default)
163	Brightness (Backlight Level)	Unsigned 16	0..20	0..20 (default 5)
164	Display Humidity	Unsigned 16	0..1	0 = Disabled 1 = Enabled (default)
165	Show Swap Temperature Units Icon	Unsigned 16	0..1	0 = Disabled (default) 1 = Enabled
166	Zone 1 Room Sensor Text	Unsigned 16	0..16	1 = Room (Default) 2 = Floor 3 = Outside 4 = Zone 1 5 = Zone 2 6 = Zone 3 7 = Bathroom 8 = Sauna 9 = Bedroom 10 = Kitchen 11 = Cooler 12 = Flow 13 = Hot Water 14 = Tank 15 = Pool 16 = Cabin

Register	Parameter Description	Data Type	Raw Data	Range
167	Zone 2 Floor Sensor Text Default: 2 = Floor	Unsigned 16	0..16	0 = Disabled 1 = Room 2 = Floor 3 = Outside 4 = Zone 1 5 = Zone 2 6 = Zone 3 7 = Bathroom 8 = Sauna 9 = Bedroom 10 = Kitchen 11 = Cooler 12 = Flow 13 = Hot Water 14 = Tank 15 = Pool 16 = Cabin
168	Zone 3 Outside Sensor Text Default: 3 = Outside	Unsigned 16	0..16	
169	Alarm 1 Source	Unsigned 16	0..3	0 = CO2 1 = Room (Temperature) 2 = Humidity 3 = None (Default)
170	Alarm 1 Amber Switching Point	Unsigned 16	0..5000	0..5000 (Default 0)
171	Alarm 1 Red Switching Point	Unsigned 16	0..5000	0..5000 (Default 0)
172	Alarm 1 Hysteresis	Unsigned 16	0..5000	0..5000 (Default 0)
173	Alarm 2 Source	Unsigned 16	0..3	0 = CO2 1 = Room (Temperature) 2 = Humidity 3 = None (Default)
174	Alarm 2 Amber Switching Point	Unsigned 16	0..5000	0..5000 (Default 0)
175	Alarm 2 Red Switching Point	Unsigned 16	0..5000	0..5000 (Default 0)
176	Alarm 2 Hysteresis	Unsigned 16	0..5000	0..5000 (Default 0)
177	Override Lights Notes: After overriding the level the parameter returns to 0. The lights object takes the last action (network or user). Notes: Override Level 1 is the next level after 0% and depends on the configuration. For On/Off = 100%, for 3-levels = 50%, for 4-levels = 33%. And so on.	Unsigned 16	0..5	0 = None (default) 1 = Override Level 1 (0%) 2 = Override Level 1 (100%-On/Off, 50%-3 Levels, 33% - 4 Levels) 3 = Override Level 2 (100%-3-Levels, 66% - 4 Levels) 4 = Override Level 3 (100% - 4 Levels)
178	Override Blinds Notes: After overriding the level the parameter returns to 0. The blinds object takes the last action (network or user). Notes: Override Level 1 is 100% for On/Off config, 25% for 4-steps config.	Unsigned 16	0..5	0 = None (default) 1 = Override Level 0 (0%) 2 = Override Level 1 (25/100%) 3 = Override Level 2 (50%) 4 = Override Level 3 (75%) 5 = Override Level 4 (100%)
179	Override Lock Mode Notes: After overriding the Lock to On/Off the parameter returns to 0.	Unsigned 16	0..2	0 = None (default) 1 = Override On 2 = Override Off
180	Maintenance Mode Password	Unsigned 16	0..9999	0000...9999 (default 6666)
181	Staff Code	Unsigned 16	0..9999	0000...9999 (default 0000)
182	PWM1 Cycle (Only TRC-P-1A2T/3R2T)	Unsigned 16	0..120	0..120 None (default 30, 0=on/off)
183	Digital Output 1 Network Override (Overrides DO1 directly, local, only TRC-P-1A2T)	Unsigned 16	0..2	0 = No Override (Default) 1 = Override Output On 2 = Override Output Off
184	Digital Output 2 Network Override (Overrides DO2 directly, local, only TRC-P-1A2T)	Unsigned 16	0..2	0 = No Override (Default) 1 = Override Output On 2 = Override Output Off
185	Heating/Cooling Changeover Min Temperature	Unsigned 16	0...950	0.0...95.0°C/°F (Default 20°C)
186	Heating/Cooling Changeover Max Temperature	Unsigned 16	0...950	0.0...95.0°C/°F (Default 25°C)
187	Fan Speed Override	Unsigned 16	0..7	0 = Auto 1 = Manual Off 2 = Manual Level 1 3 = Manual Level 2 4 = Manual Level 3 5 = Manual Level 4 6 = Manual Level 5 7 = Manual Level 6

Register	Parameter Description	Data Type	Raw Data	Range
188	Fan Off Delay - Only applicable if Min Fan Level is set.	Unsigned 16	0..28,800	0..28,800seconds (Default 0) 0 = Infinite Delay
189	Aux Heating Loop Setpoint	Unsigned 16	0..950	0.0..95.0°C/°F (Default 20°C)
190	Aux Heating Loop Proportional Band	Unsigned 16	10..500	1.0..50.0°C/°F (Default 4°C)
191	Aux Heating Loop Integral Action Time	Unsigned 16	0..1200	0..1200 seconds (600s default)
192	Aux Loop Actuator Direction (actuator direction, Direct = 0..100%, Reverse = 100..0%)	Unsigned 16	0..1	0 = Reverse Action (100-0%) 1 = Direct (0-100% Default)
200	Monday / Weekday Switching Time 1	Unsigned 16	0..2400	0..2400 (Default 0600)
201	Monday / Weekday Switching Time 2	Unsigned 16	0..2400	0..2400 (Default 1000)
202	Monday / Weekday Switching Time 3	Unsigned 16	0..2400	0..2400 (Default 1300)
203	Monday / Weekday Switching Time 4	Unsigned 16	0..2400	0..2400 (Default 1700)
204	Monday / Weekday Switching Time 5	Unsigned 16	0..2400	0..2400 (Default 2200)
205	Monday Switching Time 1 Target	Unsigned 16	0..3	0 = Comfort (Default) 1 = ECO 2 = Off 3 = Boost
206	Monday Switching Time 2 Target	Unsigned 16	0..3	
207	Monday Switching Time 3 Target	Unsigned 16	0..3	
208	Monday Switching Time 4 Target	Unsigned 16	0..3	
209	Monday Switching Time 5 Target	Unsigned 16	0..3	
210	Tuesday / Weekend Switching Time 1	Unsigned 16	0..2400	0..2400 (Default 0600)
211	Tuesday / Weekend Switching Time 2	Unsigned 16	0..2400	0..2400 (Default 1000)
212	Tuesday / Weekend Switching Time 3	Unsigned 16	0..2400	0..2400 (Default 1300)
213	Tuesday / Weekend Switching Time 4	Unsigned 16	0..2400	0..2400 (Default 1700)
214	Tuesday / Weekend Switching Time 5	Unsigned 16	0..2400	0..2400 (Default 2200)
215	Tuesday Switching Time 1 Target	Unsigned 16	0..3	0 = Comfort (Default) 1 = ECO 2 = Off 3 = Boost
216	Tuesday Switching Time 2 Target	Unsigned 16	0..3	
217	Tuesday Switching Time 3 Target	Unsigned 16	0..3	
218	Tuesday Switching Time 4 Target	Unsigned 16	0..3	
219	Tuesday Switching Time 5 Target	Unsigned 16	0..3	
220	Wednesday Switching Time 1	Unsigned 16	0..2400	0..2400 (Default 0600)
221	Wednesday Switching Time 2	Unsigned 16	0..2400	0..2400 (Default 1000)
222	Wednesday Switching Time 3	Unsigned 16	0..2400	0..2400 (Default 1300)
223	Wednesday Switching Time 4	Unsigned 16	0..2400	0..2400 (Default 1700)
224	Wednesday Switching Time 5	Unsigned 16	0..2400	0..2400 (Default 2200)
225	Wednesday Switching Time 1 Target	Unsigned 16	0..3	0 = Comfort (Default) 1 = ECO 2 = Off 3 = Boost
226	Wednesday Switching Time 2 Target	Unsigned 16	0..3	
227	Wednesday Switching Time 3 Target	Unsigned 16	0..3	
228	Wednesday Switching Time 4 Target	Unsigned 16	0..3	
229	Wednesday Switching Time 5 Target	Unsigned 16	0..3	
230	Thursday Switching Time 1	Unsigned 16	0..2400	0..2400 (Default 0600)
231	Thursday Switching Time 2	Unsigned 16	0..2400	0..2400 (Default 1000)
232	Thursday Switching Time 3	Unsigned 16	0..2400	0..2400 (Default 1300)
233	Thursday Switching Time 4	Unsigned 16	0..2400	0..2400 (Default 1700)
234	Thursday Switching Time 5	Unsigned 16	0..2400	0..2400 (Default 2200)
235	Thursday Switching Time 1 Target	Unsigned 16	0..3	0 = Comfort (Default) 1 = ECO 2 = Off 3 = Boost
236	Thursday Switching Time 2 Target	Unsigned 16	0..3	
237	Thursday Switching Time 3 Target	Unsigned 16	0..3	
238	Thursday Switching Time 4 Target	Unsigned 16	0..3	
239	Thursday Switching Time 5 Target	Unsigned 16	0..3	
240	Friday Switching Time 1	Unsigned 16	0..2400	0..2400 (Default 0600)
241	Friday Switching Time 2	Unsigned 16	0..2400	0..2400 (Default 1000)
242	Friday Switching Time 3	Unsigned 16	0..2400	0..2400 (Default 1300)

Register	Parameter Description	Data Type	Raw Data	Range
243	Friday Switching Time 4	Unsigned 16	0..2400	0..2400 (Default 1700)
244	Friday Switching Time 5	Unsigned 16	0..2400	0..2400 (Default 2200)
245	Friday Switching Time 1 Target	Unsigned 16	0..3	0 = Comfort (Default) 1 = ECO 2 = Off 3 = Boost
246	Friday Switching Time 2 Target	Unsigned 16	0..3	
247	Friday Switching Time 3 Target	Unsigned 16	0..3	
248	Friday Switching Time 4 Target	Unsigned 16	0..3	
249	Friday Switching Time 5 Target	Unsigned 16	0..3	
250	Saturday Switching Time 1	Unsigned 16	0..2400	0..2400 (Default 0600)
251	Saturday Switching Time 2	Unsigned 16	0..2400	0..2400 (Default 1000)
252	Saturday Switching Time 3	Unsigned 16	0..2400	0..2400 (Default 1300)
253	Saturday Switching Time 4	Unsigned 16	0..2400	0..2400 (Default 1700)
254	Saturday Switching Time 5	Unsigned 16	0..2400	0..2400 (Default 2200)
255	Saturday Switching Time 1 Target	Unsigned 16	0..3	0 = Comfort (Default) 1 = ECO 2 = Off 3 = Boost
256	Saturday Switching Time 2 Target	Unsigned 16	0..3	
257	Saturday Switching Time 3 Target	Unsigned 16	0..3	
258	Saturday Switching Time 4 Target	Unsigned 16	0..3	
259	Saturday Switching Time 5 Target	Unsigned 16	0..3	
260	Sunday Switching Time 1	Unsigned 16	0..2400	0..2400 (Default 0600)
261	Sunday Switching Time 2	Unsigned 16	0..2400	0..2400 (Default 1000)
262	Sunday Switching Time 3	Unsigned 16	0..2400	0..2400 (Default 1300)
263	Sunday Switching Time 4	Unsigned 16	0..2400	0..2400 (Default 1700)
264	Sunday Switching Time 5	Unsigned 16	0..2400	0..2400 (Default 2200)
265	Sunday Switching Time 1 Target	Unsigned 16	0..3	0 = Comfort (Default) 1 = ECO 2 = Off 3 = Boost
266	Sunday Switching Time 2 Target	Unsigned 16	0..3	
267	Sunday Switching Time 3 Target	Unsigned 16	0..3	
268	Sunday Switching Time 4 Target	Unsigned 16	0..3	
269	Sunday Switching Time 5 Target	Unsigned 16	0..3	
300	Modbus Address	Unsigned 16	0..247	0..247 (Default 1)
301	Modbus Baud Rate	Unsigned 16	0..4	0 = 9600 (Default) 1 = 19200 2 = 38400 3 = 57600 4 = 76800
302	Modbus Parity	Unsigned 16	0..2	0 = None (Default) 1 = Odd 2 = Even
303	Stop Bits	Unsigned 16	0..1	0 = 1 Stop Bit (Default) 1 = 2 Stop Bits
400	Force Reset	Unsigned 16	0..1	0 = Normal 1 = Force Reset
401	Non Volatile Memory Update	Unsigned 16	0..1 Note 3	0 = Normal 1 = Update
403	Force Factory Defaults	Unsigned 16	0..1	0 = Normal 1 = Force Defaults
404	Screen Refresh Rate	Unsigned 16	0..2	0 = Fast (Default) 1 = Medium 2 = Slow
405	Native Temperature Units Note: Forces Default Settings to be loaded	Unsigned 16	0..1	0 = Celsius (Default) 1 = Fahrenheit
406	Language	Unsigned 16	0..1	0 = English (Default) 1 = French
407	Screen Cycle Rate	Unsigned 16	0..2	0 = Medium (Default) 1 = Fast 2 = Slow
408	Auto Daylight Savings	Unsigned 16	0..1	0 = Disabled (Default) 1 = Enabled

Register	Parameter Description	Data Type	Raw Data	Range
410	Current Hour	Unsigned 16	0..23	0..23
411	Current Minute	Unsigned 16	0..59	0..59
412	Current Day	Unsigned 16	1..31	1..31
413	Current Month	Unsigned 16	1..12	1..12
414	Current Year	Unsigned 16	2015..2099	2015..2099
415	Current Hour Update Register	Unsigned 16	0..23	0..23
416	Current Minute Update Register	Unsigned 16	0..59	0..59
417	Current Day Update Register	Unsigned 16	1..31	1..31
418	Current Month Update Register	Unsigned 16	1..12	1..12
419	Current Year Update Register	Unsigned 16	2015..2099	2015..2099
420	Update Time	Unsigned 16	0..1	0 = No Action 1 = Update

BACnet Standard Object Types Supported

No dynamic Creation or Deletion supported. Objects, and object instances, are assigned to fixed functions within the proprietary control application of the product as follows

Object	Number Of Instances	Instance Assignments
Device Object	1	
Analogue Value Please note AV1 - AV10 are Read Only	31	AV(0) –Built-In Sensor (Read/Only ²) AV(1) - RI_1 (RI1 Temperature / AI1, R/O ²) AV(2) - RI_2 (RI2 Temperature / AI2,R/O ²) AV(3) - Target (Calculated Setpoint, (R/O ²) AV(4) - Humidity (Read/Only ²) AV(5) - CO2 (Read/Only ²) AV(6) - Fan Demand (R/O ²) AV(7) - Thermic1 Demand AV(8) - Thermic2 Demand AV(9) - Nominal Setpoint (Read/Only ²) AV(10) – Heating DZ Comfort AV(11) – Cooling DZ Comfort AV(12) – Heating DZ ECO AV(13) – Cooling DZ ECO AV(14) – Frost SP AV(15) – Y1 Minimum AV(16) – Y1 Maximum AV(17) – Y2 Minimum AV(18) – Y2 Maximum AV(19) – Y3 Minimum AV(20) – Y3 Maximum AV(21) - PB (Proportional Band) AV(22) – IA (Integral Action) AV(23) – Brightness (LCD) AV(24) - Network Temp. AV(25) – CO2 SP (CO2 Setpoint) AV(26) – Humidity SP (Humidity Setpoint) AV(27) – Y1 Output ³ AV(28) – Y2 Output ³ AV(29) – Y3 Output ³ AV(30) - Aux. SP (Auxiliary Loop Setpoint)
Binary Value Please note BV0, BV1 are Read Only	9	BV(0) – DI_1 (Digital Input 1) (Read/Only ²) BV(1) – Boost Status (Read/Only ²) BV(2) - OFF Status ¹ BV(3) - ECO Status ¹ BV(4) – Lock ¹ BV(5) – Change-Over BV(6) - Update Nonvol BV(7) - DO_1 (Digital Output 1) BV(8) - DO_2 (Digital Output 2)
MultiState Value	3	MSV(0) - Device Mode (1=Comfort, 2=ECO, 3=OFF, 4 = Boost) MSV(1) - Alarm (Binary Coded - Add 1 to bit values) MSV(2) - Fan Speed Override (1 = Auto, 2 = Man_0, 3=Man_1, 4=Man_2, 5=Man_3, 6=Man_4, 7=Man_5, 8=Man_6)

Note1: Objects are used to change the mode ON or OFF. The mode takes the last action e.g. after overriding the ECO mode on via BO(1), the user can cancel the ECO mode from the screen. The present value field indicates the current state.

Note2: RO = "Read Only". Not possible to write to the object.

Note3: It is possible to override the output level without changing the Y1/Y2/Y3 mode to network. The object returns to use the internal logic value once the priority inputs have been set to 'null'.

App_Config Objects

NOTE: Application Configuration Objects expose the configuration parameters over the BACnet. However please check if your BACnet client can support Proprietary Object types to be able to access these parameters. Alternatively set the configuration parameters through the TRC touchscreen.

	Property Name /ID	Attributes	Range	Default
Required Object Properties	Object Identifier	R		proprietary-128
	Object Name	R/W		"Config1"
	Object Type	R		proprietary-128
Optional Properties	None			

	Property ID	Description	BACnet Data Type	Range
Proprietary Properties	40106	Setpoint Adjust Minimum	REAL	-20.0..0.0 °C/°F (Default -3.0)
	40107	Setpoint Adjust Maximum	REAL	0.0..20.0 °C/°F (Default 3.0)
	40110	Number of Heating Stages	Unsigned	0 = None 1 = 1-Stage (Default) 2 = 2-Stages
	40111	Heating Stage 1 Direction	Unsigned	0 = Reverse (Default), 1 = Direct
	40112	Heating Stage 2 Direction	Unsigned	0 = Reverse (Default), 1 = Direct
	40113	Number of Cooling Stages	Unsigned	0 = None 1 = 1-Stage (Default) 2 = 2-Stages
	40114	Cooling Stage 1 Direction	Unsigned	0 = Reverse, 1 = Direct (Default)
	40115	Cooling Stage 2 Direction	Unsigned	0 = Reverse, 1 = Direct (Default)
	40116	High Limit Setpoint	REAL	0..95°C/°F (Default 35.0°C)
	40117	Low Limit Setpoint	REAL	0..95°C/°F (Default 16.0°C)
	40118	Limit Ratio	REAL	0.0..5.0 (0.0=Disabled, Default)
	40120	CO2 Proportional Band	Unsigned	10..5000 ppm (Default = 300 ppm)
	40121	CO2 Control Integral Action	Unsigned	0..10,000 seconds (Default 0)
	40122	CO2 Output Direction	Unsigned	0 = Reverse Acting 1 = Direct Acting (Default)
	40124	Humidity Proportional Band	REAL	1.0...100.0 %rH (Default 20.0%)
	40125	Humidity Control Integral Action	Unsigned	0..10,000 seconds (Default 0)
	40126	Humidification Output Direction	Unsigned	0 = Reverse Acting 1 = Direct Acting (Default)
	40127	De-Humidification Output Direction	Unsigned	0 = Reverse Acting 1 = Direct Acting (Default)
	40128	Fan Speed Display	Unsigned	0 = No Display (Default) 1 = Display Only (no user adj.) 2 = 0 - 1 (0%, 100%) 3 = 0 - 1 - 2 (0%, 50%, 100%) 4 = 0 - 1 - 2 - 3 (0%, 33%, 66%, 100%) 5 = 0 - 1 - 2 - 3 - 4 - 5 - 6

	40129	Fan Speed Source	Unsigned	0 = Heating 1 and Cooling 1 Stage (Default) 1 = Heating Stage 1 2 = Cooling Stage 1 3 = Heating and Cooling Stage 2 4 = Heating Stage 2 5 = Cooling Stage 2 6 = CO2 7 = Humidification 8 = De-Humidification 9 = Maximum VAV (Cooling/CO2) 10 = Maximum Temp/Hum 11 = Aux. Loop
	40130	Min Fan Level	Unsigned	0...100% (Default 0%)
	40131	Y1 Output Mode Default: Modulating Fan	Unsigned	0 = Network Value 1 = Heating Stage 1 2 = Heating Stage 2
	40132	Y2 Output Mode Default: Heating Stage 1 Default TRC-1A4R: Heating1 Stat	Unsigned	3 = Cooling Stage 1 4 = Cooling Stage 2 5 = Modulating Fan (EC) 6 = CO2 Control
	40133	Y3 Output Mode Default: Cooling Stage 1	Unsigned	7 = Maximum VAV 8 = Maximum Fan 9 = Humidification 10 = De-humidification 11 = Amber / Red 12 = Red 13 = Heating1 Stat 14 = Cooling1 Stat 15 = Fan Stat 16 = Aux. Loop 17 = 6-Port (Valve) 18 = 6-Port Reverse (Valve)
	40143	Anti-JAM Time-out	Unsigned	0..14 Days 0 = Disabled (Default)
	40144	RI1 Mode	Unsigned	0 = Disabled (default)
	40145	RI2 Mode	Unsigned	1 = Room (NTC10 Control) 2 = Floor (NTC10 High/Low Lim) 3 = Aux. Loop 4 = Network NTC10 5 = Network 0-10V 6 = CO2 0-10V (0..2000 =0-10V) 7 = Main Loop (0..50°C=0-10V) 8 = Close for ECO (DI-mode) 9 = Open for ECO (DI-mode) 10 = Close for OFF (DI-mode) 11 = Open for OFF (DI-mode)
	40146	Outside Temperature Source	Unsigned	0 = Built-In Sensor (Default) 1 = Network Sensor
	40148	Digital Input Mode	Unsigned	0 = Close for ECO (Default) 1 = Open for ECO 2 = Close for OFF 3 = Open for OFF 4 = Heating/Cooling Change-Over 5 = Disable Cooling 6 = Contact Alarm 7 = Network Measurement 8 = Close for BOOST (CE only) 9 = Open for BOOST (CE only)
	40149	Digital Input Delay	Unsigned	0..28,800 seconds (Default 0s)
	40150	Internal Sensor Calibration	REAL	-10.0..+10.0 °C/°F
	40151	RI1 Calibration	REAL	-10.0..+10.0 °C/°F
	40152	RI2 Calibration	REAL	-10.0..+10.0 °C/°F
	40153	CO2 Calibration	REAL	-500...+500 ppm
	40154	Humidity Calibration	REAL	-10.0..+10.0 % rH

	Property Name /ID	Attributes	Range	Default
Required Object Properties	Object Identifier	R		proprietary-128
	Object Name	R/W		"Config2"
	Object Type	R		proprietary-128

	Property Name /ID	Attributes	Range	Default
Optional Properties	None			

	Property ID	Description	BACnet Data Type	Range
Proprietary Properties	40155	Lock Mode	Unsigned	0 = Lock mode disabled (default) 1 = On/Off workable only 2 = Temp settings only available 3 = All buttons disabled
	40156	Lock Mode Password	REAL	0000...9999
	40157	Boost Time	Unsigned	0 = Permanent (Default 0) 1..480 minutes
	40158	Boost Target	Unsigned	0 = Nominal SP (Temperature) 1 = CO2 SP 2 = Humidity SP 3 = Dehum SP 4 = Fan Demand 5 = Aux. Temp SP
	40159	Boost Target Value	Unsigned	0 ..5000 (default 25)
	40164	Display Humidity	Unsigned	0 = Disabled 1 = Enabled (default)
	40165	Show Swap Temperature Units Icon	Unsigned	0 = Disabled (default) 1 = Enabled
	40166	Zone 1 Room Sensor Text	Unsigned	1 = Room (Default) 2 = Floor 3 = Outside 4 = Zone 1 5 = Zone 2 6 = Zone 3 7 = Bathroom 8 = Sauna 9 = Bedroom 10 = Kitchen 11 = Cooler 12 = Flow 13 = Hot Water 14 = Tank 15 = Pool 16 = Cabin
	40167	Zone 2 Floor Sensor Text Default: 2 = Floor	Unsigned	0 = Disabled 1 = Room 2 = Floor 3 = Outside 4 = Zone 1 5 = Zone 2 6 = Zone 3 7 = Bathroom 8 = Sauna 9 = Bedroom 10 = Kitchen 11 = Cooler 12 = Flow 13 = Hot Water 14 = Tank 15 = Pool 16 = Cabin
	40168	Zone 3 Outside Sensor Text Default: 3 = Outside	Unsigned	0 = Disabled 1 = Room 2 = Floor 3 = Outside 4 = Zone 1 5 = Zone 2 6 = Zone 3 7 = Bathroom 8 = Sauna 9 = Bedroom 10 = Kitchen 11 = Cooler 12 = Flow 13 = Hot Water 14 = Tank 15 = Pool 16 = Cabin
	40169	Alarm 1 Source	Unsigned	0 = CO2 1 = Room (Temperature) 2 = Humidity 3 = None (Default)
	40170	Alarm 1 Amber Switching Point	Unsigned	0..5000 (Default 0)
	40171	Alarm 1 Red Switching Point	Unsigned	0..5000 (Default 0)
	40172	Alarm 1 Hysteresis	Unsigned	0..5000 (Default 0)
40173	Alarm 2 Source	Unsigned	0 = CO2 1 = Room (Temperature) 2 = Humidity 3 = None (Default)	

40174	Alarm 2 Amber Switching Point	Unsigned	0..5000 (Default 0)
40175	Alarm 2 Red Switching Point	Unsigned	0..5000 (Default 0)
40176	Alarm 2 Hysteresis	Unsigned	0..5000 (Default 0)
40180	Maintenance Mode Password	Unsigned	0000...9999 (default 6666)
40181	Staff Code	Unsigned	0000...9999 (default 0000)
40182	PWM Cycle (Only TRC-1A2T/3R2T)	Unsigned	0..120 None (default 30, 0=on/off)
40185	Heating/Cooling Changeover Min Temperature	REAL	0.0...95.0°C/°F (Default 20°C)
40186	Heating/Cooling Changeover Max Temperature	REAL	0.0...95.0°C/°F (Default 25°C)
40188	Fan Off Delay - Only applicable if Min Fan Level is set.	Unsigned	0..28,800seconds (Default 0) 0 = Infinite Delay
40190	Aux Heating Loop Proportional Band	Unsigned	1.0...50.0°C/°F (Default 4°C)
40191	Aux Heating Loop Control Integral Action	Unsigned	0..1,200 seconds (Default 600)
40192	Aux Loop Actuator Direction (actuator direction, Direct = 0..100%, Reverse = 100..0%)	Unsigned	0 = Reverse Acting 1 = Direct Acting (Default)
40300	Address	Unsigned	0..127 (Default 1)
40301	Baud Rate	Unsigned	0 = 9600 (Default) 1 = 19200 2 = 38400 3 = 57600 4 = 76800
40302	Parity	Unsigned	0 = None (Default) 1 = Odd 2 = Even
40303	Stop Bits	Unsigned	0 = 1 Stop Bit (Default) 1 = 2 Stop Bits
40400	Force Reset	Unsigned	0 = Normal 1 = Force Reset
40401	Non Volatile Memory Update	Unsigned	0 = Normal 1 = Update
40403	Force Factory Defaults	Unsigned	0 = Normal 1 = Force Defaults
40404	Screen Refresh Rate	Unsigned	0 = Fast (Default) 1 = Medium 2 = Slow
40406	Language	Unsigned	0 = English (Default) 1 = French
40407	Screen Cycle Rate	Unsigned	0 = Medium (Default) 1 = Fast 2 = Slow
40408	Auto Daylight Savings	Unsigned	0 = Disabled (Default) 1 = Enabled

NOTE:Information is subject to change without prior notice.

Dimensions

