

Saia PCD2/3.W380

Analogue input module

8 inputs 13-bit resolution

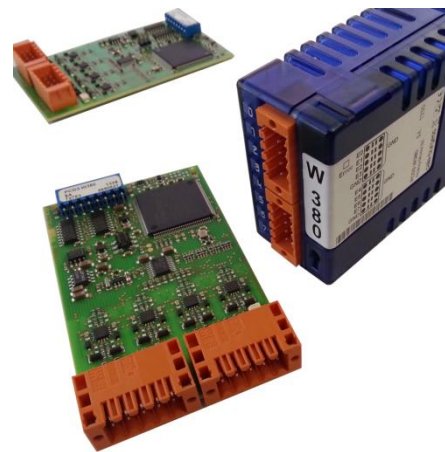

This new module is a universal analogue input module with innovative embedded features. It offers many advantages for all involved parties (project manager, programmer, panel builder and end user). The 8 analogue inputs with 13-bit resolution can be individually configured by software for the various sensor types. Opening the module case and plugging jumpers is no longer necessary. Each input has 2 connection terminals. In addition to 0...10V, +/- 10V, 0(4)...20mA, Pt/Ni 1000 also NTC10k/NTC20k temperature sensors are supported. Thanks to the numerous measuring ranges spare parts handling and service become easier, more flexible and less expensive. The precision of the inputs is 0.3% or better (based on the full range). This module can also be used in applications where the data acquisition speed is important. Each channel value is updated in internal buffer every 680us that means each input value is refreshed at 1.5 kHz. Digital filters can be configured individually for all inputs. An LED on the housing indicates module errors, which can also be evaluated in the user program. The inputs are also protected against configuration errors by the user.

Signal ranges

Mode	Resolution [Bit]	Resolution [measure]	Accuracy (@ T _{Ambient} = 25°C)	Display
Voltage -10V ... +10V	12 + Sign	2.44 mV (linear) <i>R_{IN} = 330kΩ</i>	0.2% of measured value +/- 10mV	-10'000...+10'000
Current -20mA...+20mA	12 + Sign	5.39 uA (linear) <i>R_{SHUNT} = 225Ω</i>	0.2% of measured value +/- 20uA	-20'000...+20'000
Resistance 0...2'500 Ω	12 bit	0.50... 0.80 Ω <i>Measuring current: 1.0 .. 1.3mA</i>	0.2% of measured value +/- 3 Ω	0...25'000
Resistance 0...300 kΩ	13 bit	0...10kΩ: 1...10 Ω 10k...40kΩ: 10..40 Ω 40k...70kΩ: 40..100 Ω 70k...100kΩ: 100...200 Ω 100k...300kΩ: 0.2...1.5 kΩ <i>Measuring current: 30µA .. 1.3mA</i>	0.2% of measured value +/- 40 Ω 0.2% of measured value +/- 160 Ω 0.5% of measured value +/- 400 Ω 1.0% of measured value +/- 800 Ω 2.5% of measured value +/- 5.0kΩ	0..300'000
Pt 1000	12 bit	-50...+400°C: 0.15 ... 0.25°C <i>Measuring current: 1.0 .. 1.3mA</i>	0.2% of measured value +/- 0.5°C	-500...4000
Ni 1000	12 bit	-50 ... +200°C: 0.09 ... 0.11°C <i>Measuring current: 1.0 .. 1.3mA</i>	0.2% of measured value +/- 0.5°C	-500...2000
Ni 1000 L&S	12 bit	-30 ... +130°C: 0.12 ... 0.15°C <i>Measuring current: 1.0 .. 1.3mA</i>	0.2% of measured value +/- 0.5°C	-300...1300
Diode 0...5'000mV	12 bit	1.22mV (linear) <i>Measuring current: 0.7...1.3mA</i>	0.2% of measured value +/- 10mV	0...5'000

The measuring current was chosen to be the best compromise between the resolution and the sensors self-heating effect, which is negligible for most of the sensors and applications. Even in bad measuring conditions with Pt/Ni1000 sensors with a low thermal coupling as 4mW/K, the maximal error produced by the sensors self-heating is lower than 0.3°C. For NTC10k and NTC20k temperature sensors the input must be configured in mode “Resistance 0...300kΩ”.

Block diagram

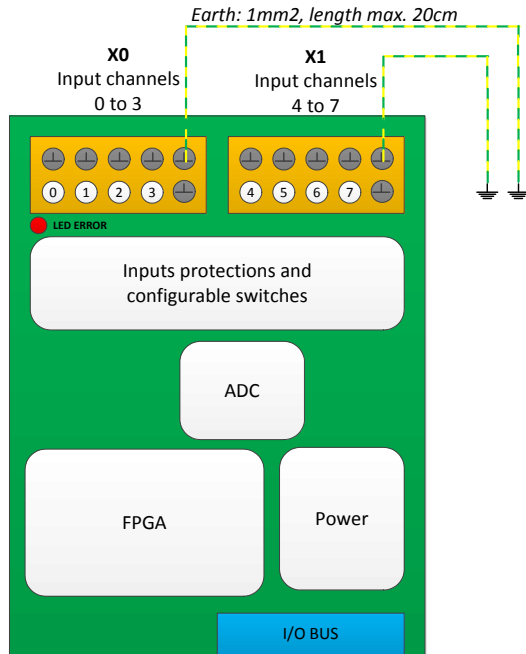

Connections

X0	1: GND	3: GND	5: GND	7: GND	9: Earth
X1	1: GND	3: GND	5: GND	7: GND	9: Earth

The inputs are connected with the module by two 10-pins connectors for wires up to 1mm². The connectors provide two pins per input channel, one for the input and one for the ground. All the ground pins are internally connected together.

Technical data

COMPATIBILITY	PCD1, PCD2, PCD3		
POWER			
Module power supply voltage	+5V and V+ IOBUS		
Current consumption	25mA on +5V and 25mA on V+		
Galvanic separation	No		
INPUTS			
Number of inputs	8		
Input ranges of each mode	-10V...+10V, -20mA...+20mA, 0...2'500Ω, 0...300kΩ, Diode 0V...5V, Pt/Ni1000, Ni1000 L&S, NTC10k, NTC20k		
Temperature error (0°C .. +55°C)	+/- 0.2%		
Inputs configuration	Each input can be configured individually in 5 modes (ranges above) in the PG5 Device Configurator		
User connector	Per channel: 1 pin for input and 1 pin for ground 2 pins for earth and 2 pins for ground in supplement		
Inputs wiring	Up to 1mm ²		
TIMING			
Refresh of each channel	680us (all channels are updated during this time)		
Hardware input filter time constant	Voltage		τ = 2.5ms
	Current		τ = 2.5ms
	Resistance	(< 2'500Ω) ¹ (typ. for R<300kΩ) ²	τ < 4.4ms τ ≈ 8ms
	Diode	(typ. for U<5V)	τ ≈ 4.4ms
Digital input filter available	No Filter	One value per cycle	τ = 680 us
	Filter 3ms:	Mean of 4 cycles	τ = 2.72 ms
	Filter 6ms:	Mean of 8 cycles	τ = 5.44 ms
	Filter 12ms:	Mean of 16 cycles	τ = 10.88 ms
Min. number of I/O Bus accesses to read one channel	28 (~28us)		

¹⁾ Temperature sensors Pt1000, Ni1000 and Ni1000L&S

²⁾ Temperature sensors NTC10k and NTC20k.

Ordering information

Model	Description	Weight
PCD2.W380	8 analogue input module for PCD1/2	40 g
PCD3.W380	8 analogue input module for PCD3	80 g

Saia-Burgess Controls AG

Bahnhofstrasse 18 | CH-3280 Murten/Schweiz
T +41 26 672 72 72 | F +41 26 672 74 99
www.saia-pcd.com

pcdsupport@saia-pcd.com | www.sbc-support.com