



HMI & PAC Solutions



Contents

ASEM	4
HMI & PAC Solutions	6
HMI Solutions - Overview	8
Premium HMI 4	10
Premium HMI Mobile	26
Ubiquity	30
HMI Solutions	44
HMI25	46
HMI30	48
HMI700	50
HMI2000	52
PAC Solutions- Overview	54
CODESYS	57
PAC Solutions	62
LP30/31	64
LP700	66
LP2000	68

Solutions for the OpenAutomation



ASEM operates since more than 25 years in the IPC market and since 10 years ASEM has been specializing in the industrial automation market.

Leading the "Open PC Automation" in Italy, ASEM is guiding the technological evolution of its customers' HMI, control and remote assistance solutions, providing "open and standard" hardware platforms integrating with innovative, flexible and easy-to-use software solutions.

Reliability

ASEM is a reliable and professional partner mastering the key technologies of automation systems.

ASEM designs, engineers and manufactures all its hardware, firmware and software solutions with an internal manufacturing process that includes board assembly.





ASEM in numbers:

- 23 millions turnover (2013)

- 140 employees

- 5.200 sqm headquarters in Artegna (UD)

- Local manufacturing unit of 3.250 sqm in Artegna (UD)

- Local R&D unit in Verona

- Local R&D unit in Giussano (MB)

- Local Sales unit in Germany

Innovation

ASEM's technological excellence is guaranteed by important investments in R&D and a continuous staff training. The ability to understand and anticipate the fast market evolution and set and follow the right strategies has enabled the company to maintain a steady growth momentum in the last 10 years.

Continuity

ASEM products and solutions have 7 to 10 years life-cycle with additional 5 years of support and repair service.

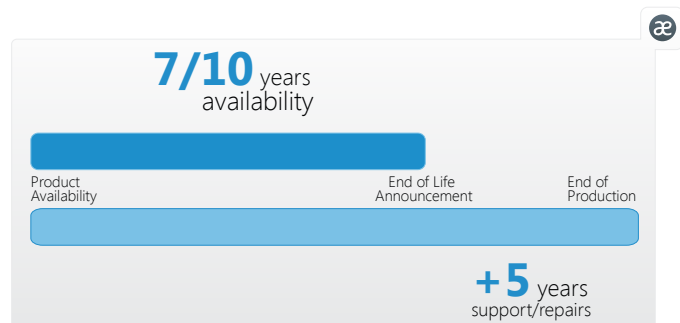

HMI & PAC

Solutions

HMI & PAC Solutions

Solutions satisfying
all your automation
requirements

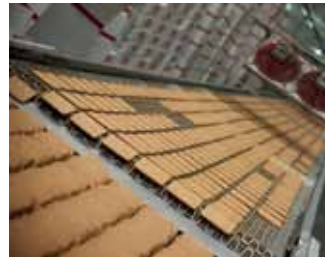

Industrial machinery design and development time reduction.

Analysis demonstrate that software development costs account for over 80% on the costs of automation design. This is the reason why it is crucial to make use of design tools capable of saving time and money in development, accompanied and supported by a company like ASEM, acknowledged for the excellence of its customer service and technical support.

Openness and flexibility to meet the specific requirements of final customers.

Today machine manufacturers need «open & standard» software solutions providing a high level of flexibility in adapting applications to specific customer needs, protecting investments and know-how.

Perfect integration of Hardware and Software.

All ASEM software solutions are integrated in hardware systems designed, industrialized and entirely manufactured in company departments and plants. The technological mastery of all the system components guarantees the high-quality level and the perfect integration between Hardware and Software platforms.

HMI Solutions



With the HMI Solutions based on Premium HMI 4 software platform, ASEM provides the market with high level HMI systems with a powerful and flexible development tool to implement open and scalable user interface projects.

Transversality is an important strength of Premium HMI 4, as it allows the same project to be used either on HMI based on ARM or X86 platforms or with WIN CE or WIN 32/64 Runtime, without the need to modify or change the settings of Premium HMI Studio development tool.

This feature is obviously appreciated by machine manufacturers who know the burdens of investments in software design and, in this way, can concentrate their focus on developing the distinctive features of their machinery.

To make Windows CE-based solutions more competitive, ASEM has decided to integrate the innovative remote assistance platform **Ubiquity** in the HMI25, HMI30, HMI600 and HMI700, making it possible to access the system and its Ethernet and Serial sub-networks from remote.

Hardware design and manufacturing combined with software development ability, allow ASEM to offer full-featured HMI solutions suited to meet all requirements, from the simplest to the most complex requiring advanced functionalities as well as openness and flexibility.

Premium **HMI**

PREMIUM HMI 4

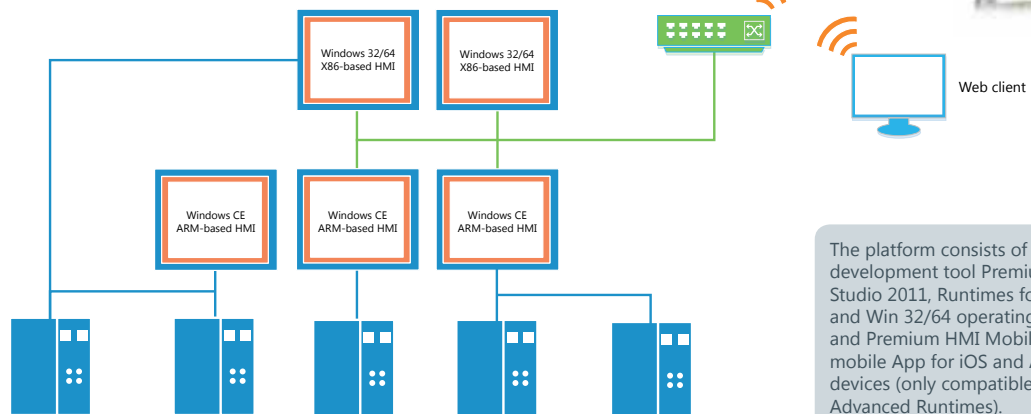

The platform consists of the development tool Premium HMI Studio 2011, Runtimes for Win CE and Win 32/64 operating systems and Premium HMI Mobile, the mobile App for iOS and Android devices (only compatible with Advanced Runtimes).

With Premium HMI software platform, ASEM has been providing valuable visualization systems appreciated for the **quantity and quality of the functionalities** available and the **transversality** of the platform which makes it possible to use the same project both on HMI solutions based on ARM or X86 hardware platforms and with WIN CE or WIN 32/64 Runtimes without any need to modify or change settings in the '**Premium HMI Studio**' development tool.

Premium HMI 4

The new PHMI4 supports the latest **Microsoft® XAML** visualization technologies that enable the design of advanced and modern operator interfaces typical of latest generation mobile devices. PHMI 4 supports **16 million colors**, manages transparency and colour shade effects, supports **new pointing "gestures"** which further improve the user experience of HMI projects, and provides a rich library of graphic objects particularly accurate from an aesthetic and ergonomic point of view making it possible to design unprecedented user interface screens. The **new XAML graphic objects library**, available for Windows CE and Windows 32/64 operating systems, comes together with the existing one, maintaining full compatibility. The user just needs to make a click of mouse in the development

tool to **convert existing projects introducing new graphic objects** without making any changes, retaining all scripts assigned to graphic objects or variables linked to properties that vary dynamically. These characteristics make PHMI4 a unique HMI platform in the competitive context and it becomes particularly interesting due to the fact that it can update the aesthetics and ergonomics of already realised projects without investing in new developments and without the need for further application tests. Another important strength is the availability of **Microsoft® XAML objects under Win CE operating system**, that makes Premium HMI 4 one of the very few platforms on the market providing this feature.

"Total Cost of Ownership" reduction

With the intuitiveness of Premium HMI's object design, the project debugging tools and the possibility to use a single development tool for any type of application (from the simplest on operator panels to the most complex on Panel PCs or the most innovative on smart mobile devices), it becomes easy to save a considerable amount of time in learning, personnel training, application maintenance and end- user support and service.

Runtime versions

To provide supervision systems able to meet different performance, functionality and price requirements ASEM offers two runtime versions for WIN CE (Basic and Advanced) and three runtime versions for WIN 32/64 (Basic, Pro and Advanced).

Function	Premium HMI 4.0 BASIC for Win CE	Premium HMI 4.0 ADVANCED for Win CE	Premium HMI 4.0 BASIC for Win 32	Premium HMI 4.0 PRO for Win 32	Premium HMI 4.0 ADVANCED for Win 32
RealTime DB	Max. 1024 byte	Max. 4096 byte	Max. 2048 byte	Max. 2048 byte	Max. 4096 byte
-rmalization	✓	✓	✓	✓	✓
ODBC Realtime	✓	✓	-	✓	✓
Trace DB	✓	✓	-	✓	✓
Data Structures	✓	✓	✓	✓	✓
OPC Client DA	✓	✓	✓	✓	✓
OPC Client XML DA	-	-	✓	✓	✓
Networking	✓	✓	✓	✓	✓
Script's IntelliSense Tags	✓	✓	-	✓	✓
Graphic User Interface					
Vector Graphics Editor	✓	✓	✓	✓	✓
XAML Vector Graphics	✓ ⁽¹⁾	✓ ⁽¹⁾	✓	✓	✓
BMP, GIF, JPG, WMF, EMF support	✓	✓	✓	✓	✓
Gesture Recognition	✓	✓	✓	✓	✓
Dynamic Animation	✓	✓	✓	✓	✓
Symbols library	✓	✓	✓	✓	✓
Import/Export Symbols	✓	✓	✓	✓	✓
Public Symbols	✓	✓	-	✓	✓
Power Template (VBA Symbols)	✓	✓	-	✓	✓
Grid	✓	✓	-	✓	✓
Synapses	✓	✓	-	✓	✓
Schedulers	✓	✓	✓	✓	✓
Editing Menu	✓	✓	✓	✓	✓
Style Reference Management in Symbols	✓	✓	-	✓	✓
Dundas Potentiometer	-	-	✓	✓	✓
IP Video Camera Window	✓	✓	✓	✓	✓
Objects' Alias Management	✓	✓	-	✓	✓
Alarms and logs	Max 512 alarms	Max 2048 alarms	Max 2048 alarms	Max 2048 alarms	Max 2048 alarms
Alarm Management	✓	✓	✓	✓	✓
Historical Management (CSV)	✓	✓	✓	✓	✓
Historical Management (ODBC)	✓	✓	-	✓	✓
Alarm -tification (SMS, E-Mail)	-	✓	-	-	✓
Alarm Areas	✓	✓	✓	✓	✓
Comment on ACK alarm	✓	✓	-	✓	✓
Recipes - Data Logger					
Recipes / Data Logger (XML)	✓	✓	Max -. 2 Data Logger, Unlimited recipes	✓	✓
Recipes / Data Logger (ODBC)	Max -. 2	✓	-	✓	✓

⁽¹⁾ XAML vector graphics supported exclusively by Windows Embedded Compact 7 and newer

Function	Premium HMI 4.0 BASIC for Win CE	Premium HMI 4.0 ADVANCED for Win CE	Premium HMI 4.0 BASIC for Win 32	Premium HMI 4.0 PRO for Win 32	Premium HMI 4.0 ADVANCED for Win 32
Reports					
Text Reports	✓	✓	✓	✓	✓
Graphic Reports and Alarm Statistics	✓	✓	✓ with limitations (access to data only through IMDB)	✓	✓
Trends					
RealTime Trends	✓	✓	✓	✓	✓
Historical Trends on .CSV files	✓	✓	✓	✓	✓
Historical Trends (linked to Data Logger XML)	✓	✓	✓	✓	✓
Historical Trends on Database (ODBC)	✓	✓	-	✓	✓
Users & Password					
1024 levels management	✓	✓	✓	✓	✓
Users' groups management	✓	✓	✓	✓	✓
CFR21	✓	✓	-	✓	✓
Runtime users	✓	✓	✓	✓	✓
Dynamic Multi-language	✓	✓	✓	✓	✓
Unicode Support	✓	✓	✓	✓	✓
Drivers					
Max number Drivers	Max -. 2	Max -. 4	Max -. 2	Max -. 2	Max -. 4
Tag Importer from PLC	✓	✓	✓	✓	✓
Event Objects	✓	✓	✓	✓	✓
-rmaliser Objects	✓	✓	✓	✓	✓
Scheduler Objects	✓	✓	✓	✓	✓
Logic					
IL Logic (Step5-Step7)	✓	✓	✓	✓	✓
VBA Logic (WinWrap Basic)	✓	✓	Reduced (Max 2 scripts)	✓	✓
Synapse Logic	✓	✓	-	✓	✓
Networking	✓	✓	✓	✓	✓
Child Projects	✓	✓	-	✓	✓
Sy-ptic Navigation	✓	✓	-	✓	✓
Integration to Visual Source Safe	✓	✓	✓	✓	✓
Web Client	-	Max 2 clients	-	-	Max 2 clients
Premium HMI Mobile	-	✓	-	-	✓
Touch Screen Support	✓	✓	✓	✓	✓
Crossed List	✓	✓	✓	✓	✓
Debugger	✓	✓	✓	✓	✓



Premium HMI communication protocols	Interface			Operating System		
	Serial	Ethernet	Add-on	Windows CE		Windows Win32/64
				ARM	x86	x86
CODESYS, ELAU, KEB, PARKER,...	-	✓	-	✓	✓	✓
Rockwell DF1 and Data Highway	✓	-	-	✓	✓	✓
Rockwell Ethernet IP	-	✓	-	✓	✓	✓
Applicon cards Applicon Cards	-	-	Applicon Cards	-	-	✓
B&R PVI with protocol INA2000 ⁽¹⁾	✓	✓	-	✓	✓	✓
B&R TCP	-	✓	-	✓	✓	✓
BACNET IP	-	✓	-	-	-	✓
Beckhoff Twincat (ADS protocol) ⁽²⁾	-	✓	-	✓	✓	✓
CANopen Master NETCoreX CANopen Master	-	-	NETCoreX CANopen Master	-	✓	✓
CANopen Slave only PDO NETCoreX CANopen Slave	-	-	NETCoreX CANopen Slave	-	✓	✓
KNX (EIBUS Konnex)	✓	✓	-	-	-	✓
ELAP	✓	-	-	-	✓	✓
FATEK	-	✓	-	✓	✓	✓
GE FANUC SNP-X	✓	-	-	✓	✓	✓
Hilscher DPM in PROFIBUS, CANopen, CIF cards	-	-	CIF Cards	-	✓	✓
Hilscher MPI CIF card	-	-	CIF Card	-	✓	✓
Hilscher NETLINK	-	✓	-	-	✓	✓
Hilscher NETX MPI NETCoreX MPI	✓	-	NETCoreX MPI	-	✓	✓
Hilscher NETX PROFIBUS Slave NETCoreX PROFIBUS SLAVE	✓	-	NETCoreX Profibus Slave	-	✓	✓
Hitachi PLC serie H	✓	-	-	-	-	✓
IBH Softech	-	✓	-	✓	✓	✓
KEB DIN66109II	✓	-	-	✓	✓	✓
LENZE LECOM AB	✓	-	-	✓	✓	✓
LonWorks	✓	✓	-	-	-	✓
Mitsubishi MELSEC A	-	✓	-	-	-	✓
Mitsubishi MELSEC FX	✓	-	-	✓	✓	✓
Mitsubishi MELSEC Q	✓	✓	-	✓	✓	✓
Mitsubishi FX3U TCP	-	✓	-	-	-	✓
Modbus RTU Master / Slave	✓	-	-	✓	✓	✓
Modbus TCP IP	-	✓	-	✓	✓	✓
Moeller SUCOM	✓	-	-	✓	✓	✓
OMRON EtherNET/IP	-	✓	-	✓	✓	✓
OMRON FINS	✓	✓	-	✓	✓	✓
OMRON Host Link	✓	-	-	✓	✓	✓
PANASONIC FP MEWTOCOL	✓	✓	-	✓	✓	✓
ROBOX	-	✓	-	✓	✓	✓
SAIA via SCOMM DLL	✓	✓	-	-	-	✓
SAIA S-BUS	✓	✓	-	✓	✓	✓
SCHNEIDER UNITELWAY SLAVE	✓	-	-	✓	✓	✓
SIEMENS MPI PC ADAPTER	✓	-	-	✓	✓	✓
SIEMENS S5 CPU	✓	-	RS-232 to Current Loop Converter	✓	✓	✓
SIEMENS S5 DK3864R	✓	-	-	✓	✓	✓
SIEMENS S7 200 PPI	✓	-	-	✓	✓	✓
SIEMENS S7 300/400 MPI	✓	-	-	✓	✓ ⁽³⁾	-
SIEMENS S7 TCP 300/400/1200 ⁽⁴⁾	-	✓	-	✓	✓	✓
SIEMENS SAPI S7 SIEMENS CP5611, 5613, 5614, 5412 e SIEMATIC NET	✓	-	SIEMENS CP5611, 5613, 5614, 5412 e SIEMATIC NET	-	-	✓
SIEMENS Simotion	-	✓	-	✓	✓	✓

⁽¹⁾ Requires PVI communication driver libraries from B&R

⁽²⁾ Requires ADS communication driver libraries from Beckhoff

⁽³⁾ Only OT600/HMI600/Smartbox

⁽⁴⁾ Communication with S7-1200 controllers is supported only with absolute addressing (no symbolic)



Premium HMI Features

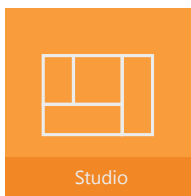
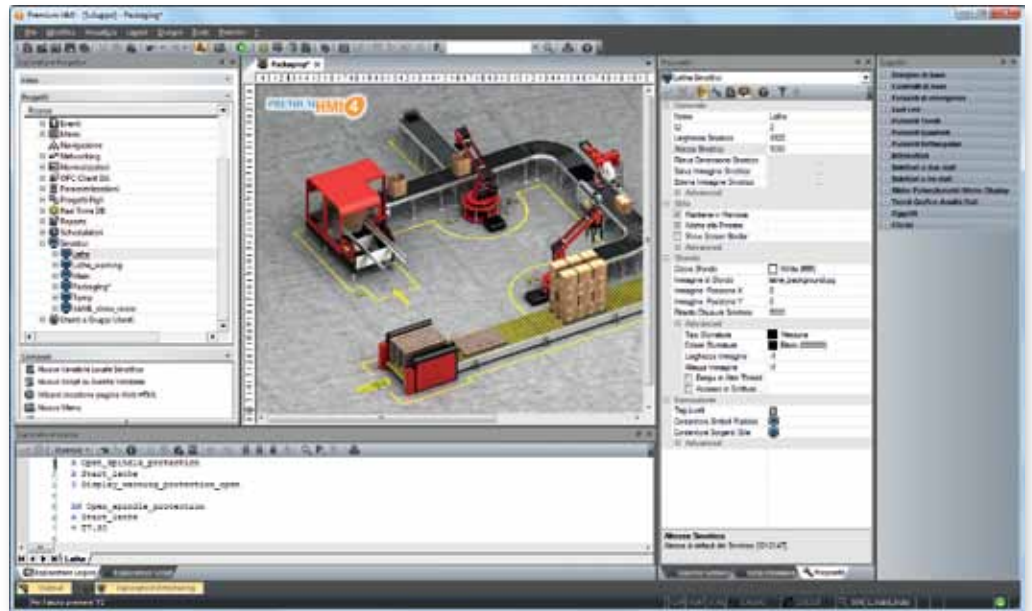

Premium HMI Studio 2011
A unique development tool to realize HMI projects for Windows CE and Windows 32/64 operating systems on ARM and X86 hardware platforms

→ **Object-oriented programming** to drastically reduce use of code in project development, thus saving time not only in designing but also in project debugging and maintenance
→ **Ergonomic** and highly configurable **development tool** (floating and traditional windows, shortcuts and configuration pop-ups) to fully adapt to every kind of requirement

→ **Wizard for project quick development** (templates, automatic creation of project pages, title headings, navigation keys, alarm model and Data Logger model)
→ Project explorer with **hierarchical tree view of resources** (selection of multiple objects and single components of a group, copy/paste function support)
→ Support of **level programming** with level visibility management (configured objects of the various synoptics can be attributed to different levels)

→ **Distributed project planning** with support of **"Father project / Child project"** philosophy which dynamically links and integrates decentralised projects (the Father project includes all the resources of the Child project as if they were its own)
→ Export and import of variables, languages and translations, alarms and logs in .CSV format
→ Wide **graphic symbols library** (also with integrated animation logic), organised in categories with immediate display of preview and Drag&Drop in synoptics. Possibility to create new symbols and new categories.



Latest generation graphic user interface
Premium HMI offers the most advanced graphic technologies based on XAML standards and it is the only visualization solution supporting XAML vector graphics also on Windows CE operating system.
 → Premium HMI 4 introduces a **new 16 million colors graphic rendering engine** supporting XAML advanced graphic technologies
 → Sophisticated management of **transparency and shading effects**

→ **Automatic re-dimensioning of screens** for devices with different graphic resolutions; this feature of Premium HMI allows existing projects to be easily reused on different systems regardless of the graphic resolution of the display
 → **Rich gallery of vector graphic objects** (buttons, switches, analogue displays, sliders, etc.) to realise unprecedented user interface projects

→ Complete set of **graphic animations** (including movement of objects along definable routes)
 → **«Alias» support and inheritance of symbols** with definition of public symbols and automatic propagation of modifications from parent object to child object
 → Integrated support for multi-monitor systems

Recognition of graphic pointing gestures
Support of “swipe” gestures for an intuitive and easy page change
 → Gesture recognition is also supported by Windows CE-based systems

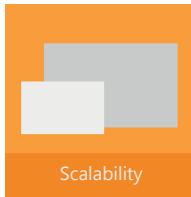

Scalability

Scalability

Premium HMI offers a unique development environment to realise the user interface of all ASEM HMI solutions based on ARM Cortex and X86 architectures with Windows CE and Windows 32/64 operating systems

→ Premium HMI allows the company to keep just one software platform to meet all visualization needs, from the simplest projects to more demanding supervision applications, thus saving time in learning, updating and personnel training

Connectivity and communication

Premium HMI has a complete communication drivers library for the most used PLCs on the market

→ Specific **wizards** allow the import and automatic configuration of **project Variables** (Tags) directly from the PLC project, reducing configuration time and errors

→ Premium HMI 4 integrates **OPC Client** technology (the product meets the certification criteria established by the OPC Foundation)

Premium HMI also provides:

→ High performance and reactivity of controls to meet the most demanding requirements of machine manufacturers that need **fast**

data updating and a prompt dispatch of commands to actuators

→ Support for **multi-protocol** interfacing with data transfer function (**gateway**) between communication channels

→ Real-Time I/O ODBC Link provides connectivity towards company's information systems. Each variable (Tag) has the reading-writing

connectivity to an **external relational DB**. Therefore the Real-Time DB of the project can be shared automatically (partially or entirely) on a DB table, allowing sharing of plant's real-time data with the company's ERP

→ Availability of normalisers for the application of **non-linear transformations** to the variables

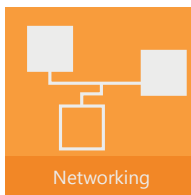

Networking

Networking

Premium HMI 4 has sophisticated Networking technology able to connect different HMI stations via Ethernet with multilevel Client/Server architecture

→ The Client/Server architectures are supported by integrated functionalities that allow online distribution of both dynamic information and projects

→ Local execution of Client projects works by loading the project from servers

→ Efficiency and performance are guaranteed by the "**event-driven**" architecture for data synchronisation

→ The **server stations** can be based indifferently on **Windows CE or Windows 32/64**

Openness and flexibility

Premium HMI is based on XML, ODBC, OPC, VBA, TCP/ IP and SQL standard technologies, integrated in the platform to guarantee easy access and data transparency

→ Projects are stored in XML format, which can be edited even with external Editors

→ Support of data sharing on shared memory

→ Data storage management on relational database (MS SQL Server, Oracle, MySQL, MS Access, SQL, etc.)

→ Native support of Microsoft Visual Source Safe, a tool allowing online management of projects which is very used by development teams to

guarantee security, multi-users, changes traceability, maintenance and recovery of project versions



Data logger, Trends and Data Analysis - Traceability of data and historical archives

The Data Logger is the main tool for process data recording.

In addition Premium HMI offers sophisticated tools such as Trends and Data Analysis objects to analyse and represent logged data

- Simple configuration of process data sampling options
- Data can be recorded by frequency (time), or at event or variation (with dead band)
- Data storage on Database and text file both in local and remote

→ **Trends** are graphic objects representing curves regarding the tendency of process data

→ Trends can be either dynamic or historical and have multiple features to represent values graphically. They are directly linked to Data Loggers and allow you to represent data by time period or other types of filters, zooms, pen selection, logarithmic scale, average value, compressed representation of the whole graph on one page, etc.

→ Data Analysis objects are more sophisticated than Trends and allow you to analyse and graphically represent logged data recorded by Data Loggers

→ **Data Analysis objects** execute quick analyses at pre-set periods, comparisons and overlapping of curves (analyses with sample curves or comparative analyses of different periods, difference between values of two different graphs, etc.)

Premium HMI provides also:

- Traceability of variable modifications, with storage of the old and new value and modification's author
- Visualization of events history both from local database and network server (view of server HMI alarms from Client interface)
- Data archive export in .CSV format

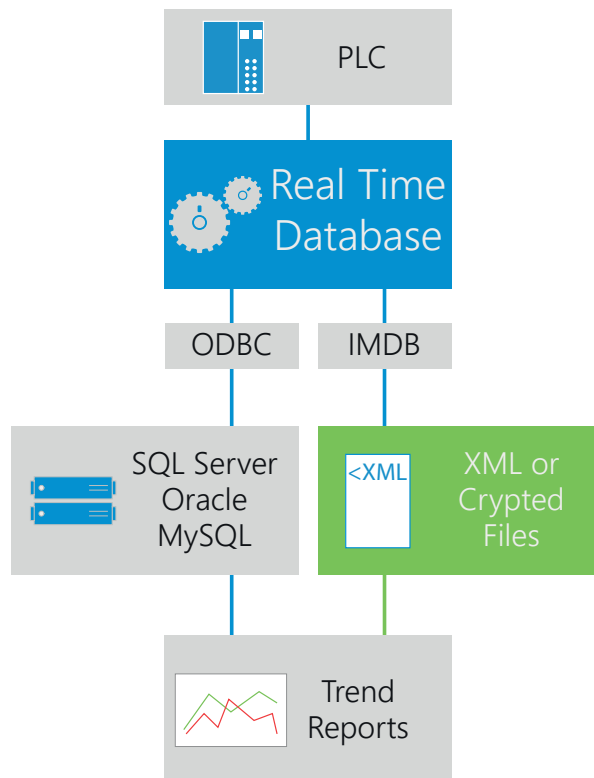

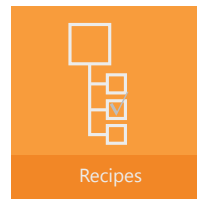

Recipe manager

Production recipes allow you to manage archives containing operating parameters of the production process of different products

- Production recipes are managed by objects with the same recording techniques as Data Loggers, both on Database and on text files
- Selecting the desired product it is possible to activate parameter values relating to the process variables
- Possibility to have multiple recipe structures inserted inside one another to design complex modular machines
- Simplified configuration with project structures for recipe use.

The object technology allows you to create a “recipe” object and, once the relative variable has been assigned to it, a specific “wizard” automatically generates the recipe management window, with a fully customisable user interface (fonts, colours, etc.)

- As an alternative, a simple grid viewer object allows you to manage recipe data traditionally
- Recipe data can be exported and imported in .CSV format

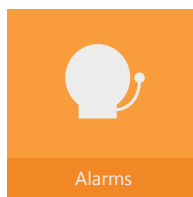
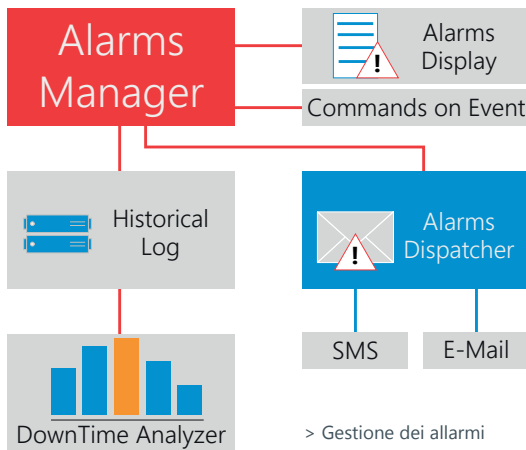

Alarm manager

Premium HMI provides maximum reliability in events management, guaranteeing continuous and immediate system/machine monitoring, improving its efficiency and minimising production downtime

- Alarms are managed according to **ISA S-18** standards but they are entirely customizable with high-configurable objects and templates-oriented programming (threshold alarms, digital alarms, warning messages without recognition cycle, etc.)
- Simple definition and configuration of repetitive alarms using templates
- Fixed or variable triggering thresholds determine activation of the alarm, managing the four standard operating statuses (ON,

OFF, ACK and RST) and the consequent representation of Active Alarms in visualisation objects, managed by Windows or Banners with several filters (by time, area, priority, period, etc.) and the possibility to combine dynamically help and wizards on external files (CHM, HTML, PDF)

- Library tools for the organic visualization of active alarms, alarms awaiting acknowledgement and the alarm log with the possibility to apply visualization filters for a simple search and analysis
- The **Alarms Window** and the **Historic Log Window** are the tools to visualize active or stored alarms and can be inserted and configured as objects in any screen
- Premium HMI introduces the possibility to select an active alarm and directly view its **history in the alarm window**

- The Alarm Log automatically records all the events (Alarms, Driver Events or System Events) on the relational database (even on Windows CE) or on text files
- Alarm Dispatcher to promptly send alarms or messages via **SMS** or **E-mail**; the notification is sent to the specific User or Group of Users and can be customised depending on timetables, calendars, work shifts, etc.

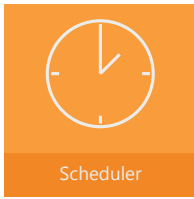

Scheduler and Event generator
Scheduler objects offer maximum configurability, in Runtime, of commands executed on a temporal base

→ Premium HMI schedulers manage **time-based programming** of any control, with flexibly configurable

timetables. The operator has full freedom to establish commands, events and periods

→ The schedulers are supported also by Windows CE and Web Client
 → "Event Objects" define lists of commands that can be flexibly configured

"Event Objects" drastically reduce the need to use code, executing command actions associated to events generated by variables (Tags) or by actions bound to command objects (e.g. buttons, menus, etc.)



Security and standards
Premium HMI 4 applications guarantee maximum level of safety and reliability in compliance with CFR21 part 11 standards

→ Users and Passwords management has been expressly designed to guarantee simple and integrated implementation of projects conforming with the severe **CFR21 part 11** standards of the

American **FDA** (Food & Drug Administration)

→ Maximum protection of data and system access by managing criteria according to **1024** User levels and **16 access areas**

→ Data recording (Data Loggers, Events or any other data) is performed both on safe relational database (e.g. Ms SQL Server or Oracle) and in proprietary format (.DAT or .XML formatted

text) encrypted with 128 bit encryption

→ Additional tools: electronic signature, control of tampering attempts, password expiration, automatic log-off and management of **Audit Trails**



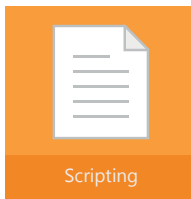

Scripting and integrated languages

Premium HMI 4 integrates a powerful VBA Engine (both for Windows CE and for Windows 32/64), able to execute codes that are perfectly compatible with the VBA standard (Visual Basic for Application) and to use a wide range of API for the most different project features

→ Scripts can be executed as normal routines or “encapsulated” in objects in response to events (graphic objects, alarm objects, data loggers etc.)
 → Scripts support **multi-threading**, the simultaneous execution of different scripts. Premium HMI provides also:
 → **VB.Net** syntax support and management of software components based on .Net

technology (only on Windows 32/64)

→ VBA expression generator to edit **logic expressions** directly on objects instead of assigning variables
 → Support of sequential combinational language, typical of PLCs (Instructions List IL or AWL)
 → Openness to integration of ActiveX, OCX, DLL software components

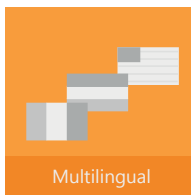

Multi-language support

Each Premium HMI project can contain all the text strings in a virtually unlimited number of languages and with any Unicode character, even with UTF-16 code for Asiatic and Arab characters

→ Editing texts in different languages is facilitated by import/export tools.

Texts are managed in the project string table, compatible with Copy/Paste operations of Editors like Microsoft Excel

→ Any language can be changed and activated both in Editor and in Runtime modes
 → A specific language can be activated when a specific Audit Trail user logs on

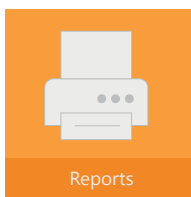

Print reports

Premium HMI integrates a simple and flexible tool in the development environment to make multi-language printing reports

→ Possibility to fully customize printing pages with Copy/Paste operations of variables and objects from the project pages (even graphs like trends, plotters, etc.)

Premium HMI provides also:

→ Printing of objects with values which change dynamically over time
 → Printing of variables present in the Data Logger both on the Database and in .CSV format
 → Printing on file, **printer** and creation of **PDF files**



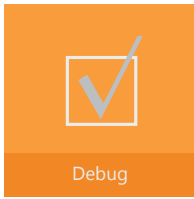

Debug

Debugging tools
Premium HMI has an integrated simulator to execute debugging without transferring the project in the target. The simulator allows communication with the protocols configured in the project

→ Powerful **online debugger** to analyse and simulate the project both locally and remotely (even during execution)

→ Possibility of full project recovery from the target hardware device for a safe and protected modification of the password (with re-transmission of the modified project to the target device)
 → In case of multi-language projects, control/verification of non-translated text strings

Premium HMI provides also:

→ Verification and reporting of variables not used in the project (**Cross Reference**)
 → "Refactoring" tools for the automatic design error correction

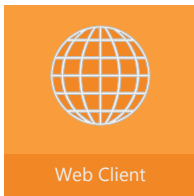

Web Client

Support for Web Client remote control
Premium HMI offers the best Web Client technology with remote access independent from local operation

→ Remote control of projects with "**Premium HMI Mobile App**" for iOS and Android

devices (needs Premium HMI 3.0.1102 or later releases)
 → The Web Client with JAVA-based architecture allows the server and projects to be accessed via **Internet browser** from any platform and operating system

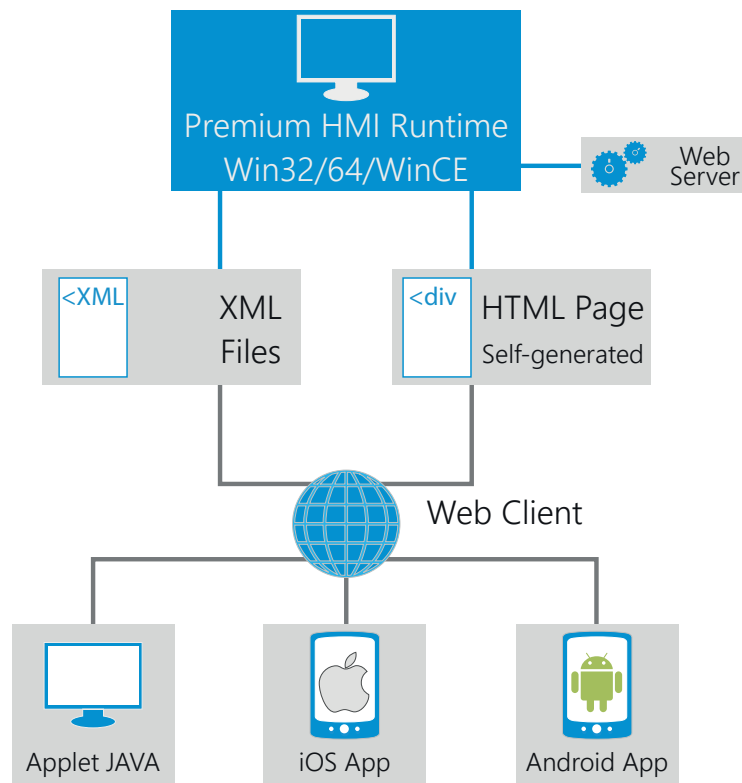

Premium **HMI** **Mobile**



PREMIUM HMI mobile

Premium HMI Mobile is the new App released by ASEM to view and interact with Premium HMI projects, running on Machine HMIs, via mobile devices (iOS and Android) connected to the enterprise Wi-Fi network. The new app provides mobile and multitouch support to the HMI project running on Machine Operator Panels/ Panel PCs.

Premium HMI Mobile requires Premium HMI "Advanced" Runtime licence and it is available for free on App Store and Google Play.

Benefits of Premium HMI Mobile App

Better control in production lines

With Premium HMI Mobile, machinery supervision becomes more flexible and efficient. The user can control machines directly from the factory floor, even in large plants or applications with several production lines.

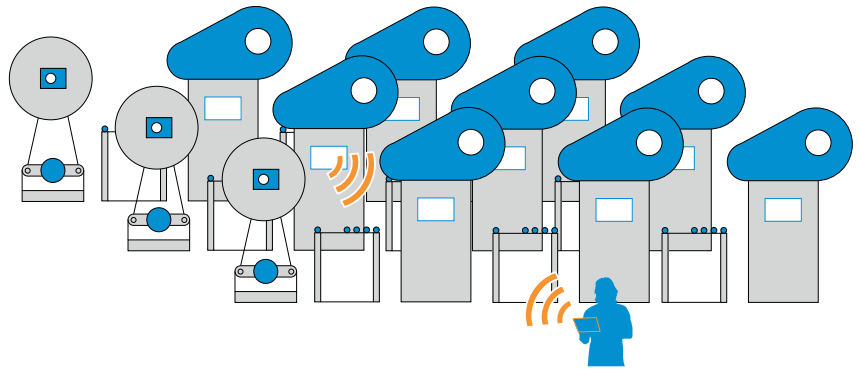

Independent project visualization

→ The native configuration of Premium HMI web server, allows you to independently manage projects on PHMI Mobile, while the local user can continue working on the machinery HMI.

→ Premium HMI Mobile manages the iOS/Android device screen resolution independently from the machine LCD resolution.

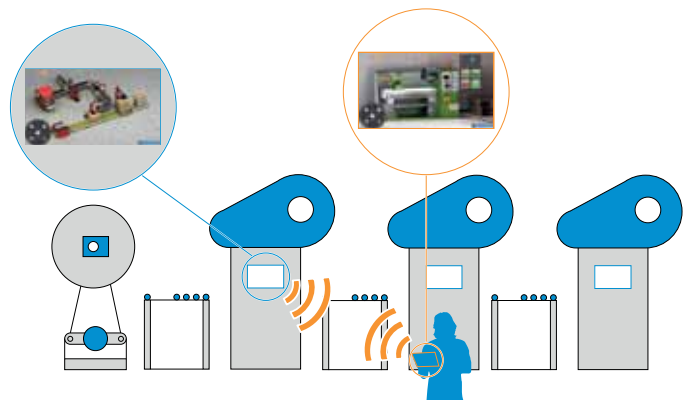

Security and users management

Premium HMI mobile supports the same security and user management features of Premium HMI. The access to pages and commands can be controlled as any Premium HMI project. Whether the application has access protection, all Premium HMI Mobile sessions will be exclusively activated through access credentials.



Premium HMI Mobile Configuration



1 Enable Premium HMI Mobile connectivity with Premium HMI Studio

To run a project on Premium HMI Mobile, the user has to include the "System Variables" by right-clicking on the Variable database icon and selecting "Add System Variables".

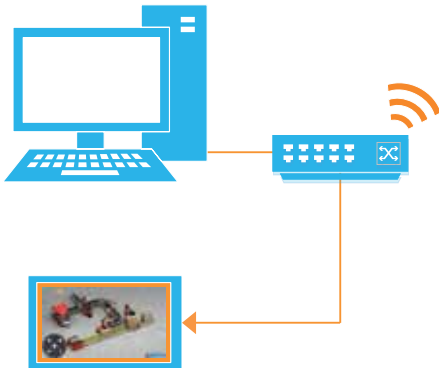

2 Connect the mobile device to the wireless infrastructure network

When the project is transferred to the Panel PC / HMI, the device must be connected to the wireless network which will be used by the iOS/Android device¹.

1. Premium HMI Mobile performances may vary according to wireless signal strength and to the processor of the device running Premium HMI Runtime "Advanced" licence.

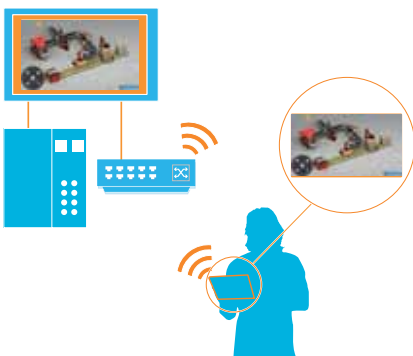

3 Connect the mobile device to the IPC / HMI

Once the installation of "Premium HMI Mobile" on the iOS/Android device is completed, connect it to the wireless network, insert access credentials on the home screen (IP address, screen name, username, password and resolution desired) and click on the connection button to start remotely interacting with the project.

Ubiquity

Ubiquity

The innovative remote assistance solution



In 2011 ASEM presented Ubiquity, the innovative software platform for remote assistance and control.

The development idea came up to solve customer requests for an easy-to-use tool to install and setup machinery and, in particular, to manage post-sales service, phases during which customers often require modifications, customizations and support.

Traditionally, the most challenging aspect of meeting such needs is the availability of qualified technical resources, that would need the gift of **ubiquity**.

Designed for machine builders, the remote assistance and control solution UBIQUITY allows to operate on the remote system and its sub-networks as if it was in your own office.



The software solution UBIQUITY enables the access to remote supervision and control systems (based on Windows CE and Windows 32/64 operative systems) and to the automation devices (PLC, drive, etc), connected to the Ethernet and Serial sub-networks of the HMI/controller, through a VPN (Virtual Private Network) based on proprietary technology comparable to a cable connection.

UBIQUITY does not require additional hardware and allows to operate in remote plants as if they were directly connected to your enterprise network. It enables technical support teams to solve any issue, eliminating the need for on-site assistance, dramatically reducing post-sale service costs.

This solution is particularly useful during machine setup and commissioning, to modify and update software applications and remotely debug PLCs and other automation devices.

+ What I can do with Ubiquity

- Remotely program, debug and update HMI/IPC/ Controllers and automation devices (PLCs/drives, etc.) connected to Ethernet and Serial sub-networks
- Malfunctioning Analysis
- Software applications updates

+ How it works

- Uses a simple internet connection
- Creates a VPN between the remote assistance PC and the remote device activating sub-networks access
- Activates safety procedures with end-to-end sessions without any intermediate
- Ensures reliability and service continuity thanks to a redundant and distributed server infrastructure

Ubiquity

Value added for all automation devices



+ Highlights

- Remote control of the IPC/HMI/Controller
- Access to Ethernet and Serial devices connected to the IPC/HMI/controller sub-network
- Additional tools: remote desktop, file transfer, chat, etc.
- Proprietary VPN technology optimized for industrial communication
- Available with the same features for Windows 32/64 and Windows CE platforms
- No additional hardware required
- SSL/TLS safe connection and use of certificates
- Simple and easy-to-use interface
- Distributed and redundant server infrastructure ensuring service continuity
- Possibility to implement a private server infrastructure
- SDK (Software Development Kit) for programming the activation of the Control Center functions also by external applications
- Runtime with multiple connection support
- Built-in firewall:
 - VPN communication protocols filter
 - Higher security and bandwidth control

Ubiquity is a simple and ready-to-use solution. Its installation does not require any ICT expertise in network and firewalls configuration. It has a user-friendly interface that enables access to remote systems (PLCs, HMIs, drives, etc.) with a simple click through a VPN optimized for industrial communications.

The solution allows transparent management of remote systems as if they were connected to the enterprise network and it does not require the support of network administrators for any NAT, proxy, firewall, public IP and reserved ports.

Ubiquity adds huge value in ASEM supervision and control system, but it is also a solution delivered as a software component to install on ASEM IPCs and third parties hardware.

Ubiquity is included in ASEM Windows based HMI & PAC Solutions (HMI25, HMI30, HMI700, HMI2000, LP30, LP700, LP2000).

Ubiquity

The components

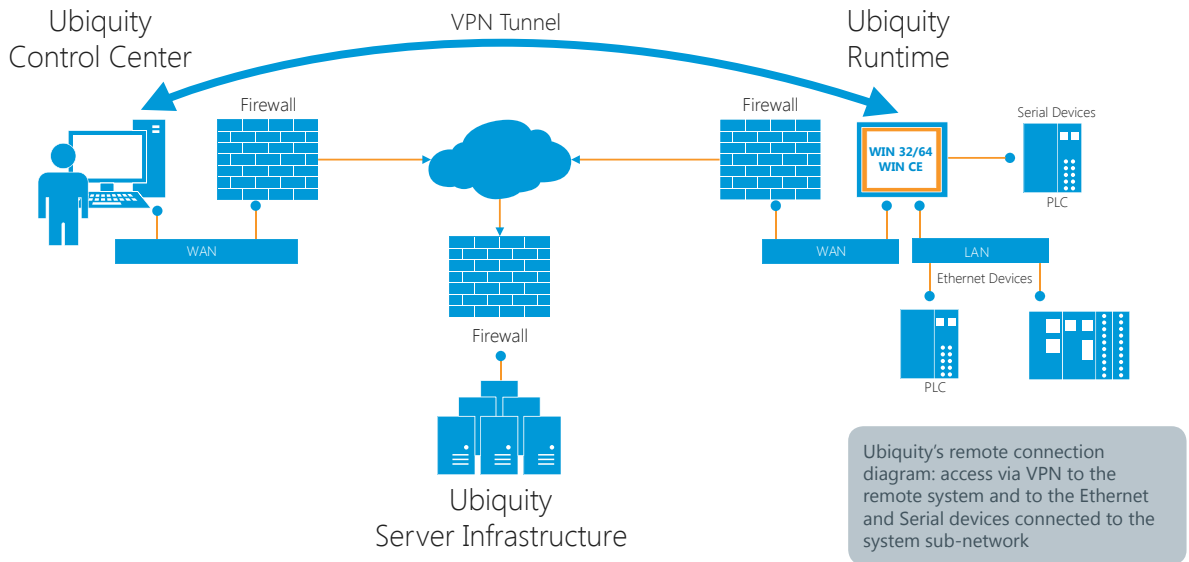

Ubiquity platform is made up of "Control Center", the software tool to be installed on the remote assistance PC to manage the "Ubiquity Domain", of the Server infrastructure and different versions of Runtime.

The connection between Control Center and the Runtime installed on the remote IPC/HMI/controller leverages on a safe end-to-end connection.

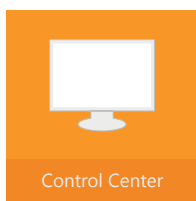

Control Center

Ubiquity Control Center
Control Center is installed and executed on the remote assistance PC and allows to manage the domain, the users and their privileges, and the connection with remote devices.

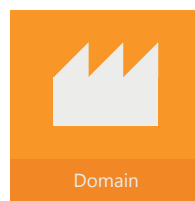

Domain

Ubiquity Domain
Ubiquity Domain is the "customer account" to make use of Ubiquity infrastructure and services.

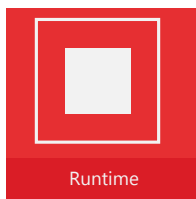

Runtime

Ubiquity Runtime
The runtime is the software component installed and executed on the remote IPC/HMI/controller that supervises or controls the automation process. It requires neither additional hardware nor network configuration and it uses the existing Internet connection.



Server Infrastructure

Ubiquity Server Infrastructure
Communication between Control Center and Runtime is ensured by a redundant server infrastructure built and maintained by ASEM which uses state-of-the-art security technologies for data exchange such as SSL/TLS, public key cryptography, safe, fault tolerant and redundant server farms to secure data privacy and adequacy.

Runtime versions

Runtime component is available in Basic and PRO versions for WIN CE and WIN 32/64 operating systems. The Basic version provides access to the IPC/HMI/remote controller and provides remote-desktop, remote task manager, remote file manager and chat with the remote operator. The PRO version enables also the access to all the automation devices (PLCs, drives, etc.) connected to the Ethernet or Serial subnetwork of the IPC/HMI/remote controller.

Ubiquity 3 Runtime	Windows CE		Win32/64	
	Basic	Pro	Basic	Pro
Remote desktop, file & task management, chat, screenshot	✓	✓	✓	✓
VPN to the remote device	✓	✓	✓	✓
VPN with access to the Ethernet sub-network of the device/router	-	✓	-	✓
VPN with access to the Serial sub-network of the device/router	-	✓	-	✓
Integrated firewall	✓	✓	✓	✓
API to interface proprietary software applications	✓	✓	✓	✓
Runtime operations persistent log	✓	✓	✓	✓
Multiple connections from different Control Center	✓	✓	✓	✓
Structured Domain creation, users and remote devices management	✓	✓	✓	✓
Internet connection via PROXY for Control Center e Runtime	✓	✓	✓	✓
Functioning in local network without license	✓	✓	✓	✓
Runtime update procedure with automatic shutdown and restart of services	✓	✓	-	-

Domain types

Ubiquity Domain is available in three different versions: Single Entity-Single Access, Single Entity-Multi Access and Multi Entity-Multi Access. Single Entity Domains are accessible by users of one only company, Multi Entity Domains are accessible by users of different companies. Single Access Domains give access to Ubiquity infrastructure and services to one user at a time, Multi Access Domains give access to Ubiquity infrastructure and services to more users at the same time.

	Ubiquity Domain types		
	Single Entity-Single Access	Single Entity-Multi Access	Multi Entity-Multy Access
Domain accessible by	Users of one company	Users of one company	Users of more companies
Remote assistance services enabled for	One user per time	More users at the same time	More users at the same time

Server infrastructure

To provide an excellent service ASEM built a redundant and globally distributed server infrastructure that counts two farms in Europe (Munich and Amsterdam), two in the United States (western and eastern coast) and two in Asia (Singapore and Honk Hong).



ASEM Server Infrastructure, does not give any limitation to the number of configurable users, devices, concurrent remote desktop and VPN sessions.

Private Server Infrastructure

As ASEM provides a redundant and distributed Server infrastructure to manage Ubiquity services, it is possible to replicate and build up a **private server infrastructure** managed autonomously.



Private Server

With the Private Server package, it is possible to install a private server infrastructure in complete autonomy. The server application can be installed on dedicated systems or cloud servers.

The **Primary Server** is the basic software package and provides authentication security and communications as the ASEM server infrastructure.

Primary Server:

- Data storage: authentication, permission and security management
- Ubiquity Runtime licenses management
- Relay feature to implement end-to-end communication

The **Secondary Server** is an optional package to improve and increase the connectivity performances. It is possible to buy several secondary server licences and install them in different locations worldwide.

Secondary Server (option):

- Relay feature to implement end-to-end communication
- You can install multiple instances to reduce latency and balance traffic load.

Ubiquity Highlights



Proprietary VPN
Differently from VPNs based on the IP layer, Ubiquity VPN works on the data-link layer bringing concrete advantages:
 → Remote assistance PC becomes part of the remote host network using the same physical IP addresses

→ Remote assistant can use broadcast-based protocols
 → It is not necessary to configure the gateway of the remotely accessed devices. The remote assistant connection appears as a locally connected IP.



Remotation of Serial Communication
 Ubiquity installs a virtual serial port on the Control Center PC.

This virtual serial port can be mapped on a physical port of the remote device executing Ubiquity Runtime.

Benefits:
 → Possibility to carry out supervision and diagnostics tasks on remote serial devices.



Multi-client
 Ubiquity Runtime supports multiple concurrent connections from different supervisors whether with interactive session (remote

desktop, file transfer, etc) or in VPN. Control Center can activate multiple interactive sessions with different devices and only one VPN connection to a remote device.

Benefits:
 → Maximum productivity being able to operate simultaneously on the same system.

Full compatibility with the existing firewalls
 Ubiquity Control Center and Ubiquity Runtime connection are automatically configured

using outbound connections which are recognized as safe and therefore allowed by firewall policies.

Benefits:
 → No need to configure the end-user's firewall and network. Only an outbound connection is necessary.

→ Ubiquity automatically uses enabled TCP and UDP protocols and can use HTTP, HTTPS or custom ports, ensuring compatibility with existing IT policies.



Industrial Security
 Ubiquity infrastructure uses the highest network security standards, such as:

→ SSL/TLS protocol via UDP or TCP
 → Asymmetric cryptography and X509 certificates for authentication sessions

→ Symmetric cryptography for data transmission
 → Message authentication codes (MAC) for data integrity.

Ubiquity Highlights

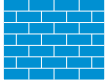

Integrated firewall

Ubiquity's integrated firewall allows to control communication packets passing through the VPN. Introducing firewall policies, it is possible to filter Ethernet datagrams depending on communication protocols and target addresses.

The server infrastructure provides a library of policies that can be imported into the Domain and applied to devices and folders. Filtering rules can be assigned to single users or group of users.

Benefits:

- Increased security and bandwidth control
- Increased flexibility in access permissions.



Access profiling and control

Ubiquity allows the creation of an unlimited number of users, user groups, device groups, each with different access rules. Permissions can be flexibly configured up to the single device or folder: possibility to create local and global users, and sub-domains.

Ubiquity provides 4 different user profiles: **Administration** enables folders and users management, **Device Installer** allows to add new devices in the Domain, **Network security** enables configuration and set up of Firewall rules and **Remote access** allows to practice remote access sessions.

Benefits:

- Users can implement their own organizational structure (made up of users, administrators, power-users, third parties, limited users, etc.) to reach in a flexible and controlled way all customers around the world
- Access to remote devices is properly secured and restricted to the required personnel.



New user interface

With a completely redesigned graphic interface based on Modern-UI standards. The new design gives additional controls and views,

as the new table view that enables the "Search" function using the text field on the right of the tree view that now gives also users (or groups of users) information.

Benefits:

- Ubiquity Control Center becomes clearer and more intuitive
- Users' daily operations are simplified and made more immediate.

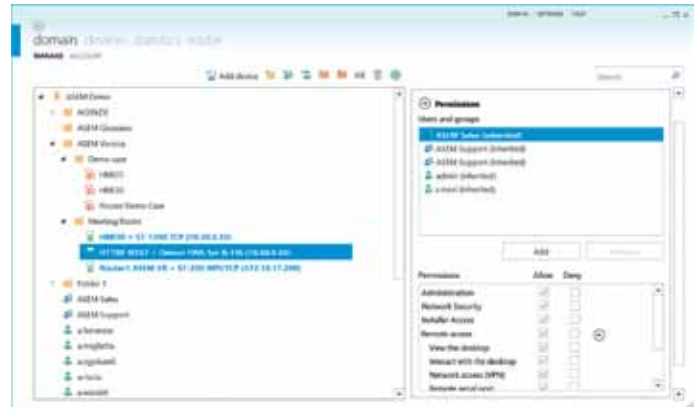
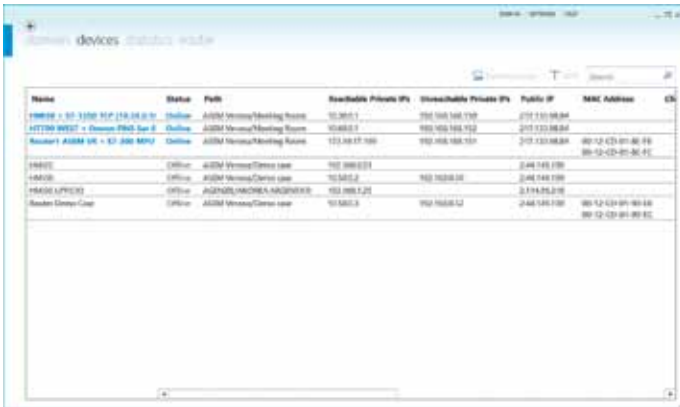

SDK Control Center

With the SDK (Software Development Kit) it is possible to program the activation of Ubiquity Control Center functions also by external applications. Control Center SDK is made of a .NET assembly and a user manual for the usage of the

API (Application Programming Interface) with the related code examples. **With the available interfaces you can execute the following tasks:**

- Domain login/logout
- Browse domain
- Connect/disconnect remote device
- Connect/disconnect VPN

- Connect/disconnect virtual serial
- File transfer to and from the remote device
- Launch application on the the remote device
- End process and restart

Ubiquity Highlights



Remote desktop

Control center includes remote desktop function.

Benefits:

→ No need to activate RDP services or to install optional utilities like VNC.



File exchange

Control Center includes a complete tool to perform remote files download and upload.

Benefits:

→ No need to open shared folders or to install optional utilities like FTP servers.



Statistic and Audit

Ubiquity records and stores on the Domain all the remote access activities.

Benefits:

→ The network administrator can verify anytime the post-sales support workload, the accuracy of the jobs carried

out and get statistics for customers, PCs and operators.



Chat

Control Center and Runtime include a chat.

Benefits:

→ Instead of using the phone to communicate with remote operators, the user can simply take advantage of Ubiquity chat and reduce costs.



Cloud-based accessibility

Ubiquity domain is registered on the Cloud. This architectural paradigm allows service continuity and data safety.

Benefits:

→ Wherever the user is located, he can launch Control Center getting access to remote machines worldwide.



Full support of Embedded platforms

Ubiquity Runtime is available for the following operative systems:

→ Windows XP, Vista, 7, 8 (32 and 64 bit)

→ Windows Embedded Standard 2009, Windows Embedded Standard 7E and 7P
→ Windows CE 5.0, 6.0, Windows Embedded Compact 7.0

Connectivity quality measurement

Ubiquity provides a simple function that measures connectivity quality on both local and remote network. Performances are measured in terms of latency time, jitter and packet drop.

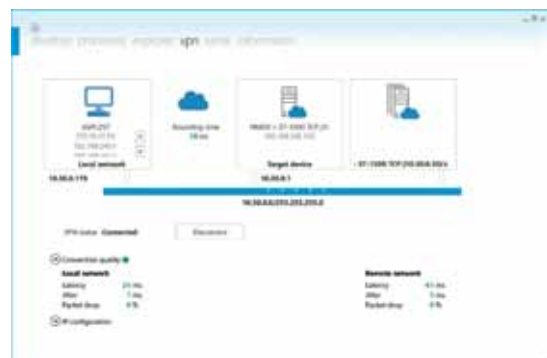

Requirements

The following tables list the minimum hardware, software and network requirements for the correct installation and usage of Ubiquity.

Control Center		
SW Requirements	Operating System	HW Requirements
.Net Framework 4.0 Client Profile	Windows XP	At least Celeron 1,6 GHz with 512 MB RAM
	Windows Vista 32-bit and 64-bit	
	Windows 7 32-bit and 64-bit	Suggested at least Pentium 4, 3 GHz, 1 GB RAM
	Windows 8 32-bit and 64-bit	
	Windows 8.1 32-bit and 64-bit	
	Windows Server 2008 and Server 2008 R2 Windows Server 2012	

Runtime		
SW Requirements	Operating System	HW Requirements
.Net Compact Framework 3.5	Windows CE 5.0 (ARM, X86)	256 MB RAM
	Windows CE 6.0 (ARM, X86)	At least CPU 500 MHz
	Windows CE Compact 7.0 (ARM, X86)	
.NET Framework 2.0 SP1 or 3.5 (distributed with setup)	Windows XP	512 MB RAM
	Windows XP Embedded	At least CPU 500 MHz
	Windows Vista 32-bit and 64-bit	
	Windows 7 32-bit and 64-bit	
	Windows 8 32-bit and 64-bit	
	Windows 8.1 32-bit and 64-bit	
	Windows Server 2008 and Server 2008 R2 Windows Server 2012	

Private Servers			
Primary Server		Secondary Server	
Hosting	Software	Hosting	Software
2 public IP addresses	Windows 7 64 bit or later Windows Server 2008 64 bit or later	1 public IP addresses	Windows 7 64 bit or later Windows Server 2008 64 bit or later
1 Internet domain name	SQL Server Express (included in the installation package) or greater (Standard, Enterprise, ...)		

HMI Solutions

 **ASEM**

PERMAINAN 4



 **ASEM**

ASEM System Manager

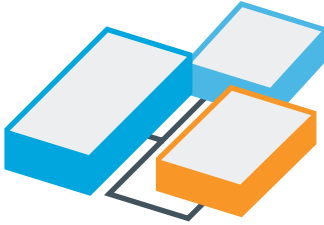

ASEM SYSTEM MANAGER
 ASEM System Manager is a set of utilities developed to improve the usage of ASEM WinCE-based ARM and x86 platforms. Installed directly in production, ASEM System

Manager is accessible from the OS control panel and includes a series of features that allow to backup the whole system or selectively backup the applications, to manage the screen saver and to implement

the antialiasing rendering for a better characters visualization. ASEM System Manager can be installed also on existing systems.

Clone, Backup and Restore

The Clone feature offers the possibility to backup the OS image (ARM systems) and the registry of the system.

Selective Backup allows to backup only specific and selected files and applications settings.

For example, select to backup the Premium HMI Runtime with the related user application, Ubiquity Runtime with its configurations and/ or CODESYS Runtime with the PLC application.

The backup is saved in a single file with ".ASR" (ASEM System Repository) extension.

With the Restore feature retrieve the backup by selecting the files to be restored.

OS update for ARM systems

The ASEM System Manager allows to update the operating system without reinstalling all the applications.

Before the update, ASEM System Manager will automatically make a temporary backup of all ASEM applications and the related settings. Once the update is completed, the backup is automatically restored in a safe and open way.

On the download area of the ASEM website there is a database with all OS image versions in ".ASR" format.

Screen Saver

The Screen Saver function allows to reduce the display brightness or to switch off the display after a period of inactivity when systems are powered but not used in a continuous way by the operator. This feature extends the lifetime of the displays.

Antialiasing

Antialiasing is a technique for minimizing the character edges compared with their matrix enabling a better character visualisation.

The utility allows to choose between two different representation, according to users preferences.

System compatibility						
Hardware platform (WinCE)	Preinstalled	Post sales installation	Backup/Restore	Backup/Restore with OS clone	Fonte antialiasing setting	Screen Saver
ARM	✓	✓	✓	✓	✓	✓
x86	-	✓	✓	-	-	-
RMxx	✓	✓	✓	✓	✓	-

HMI Solutions

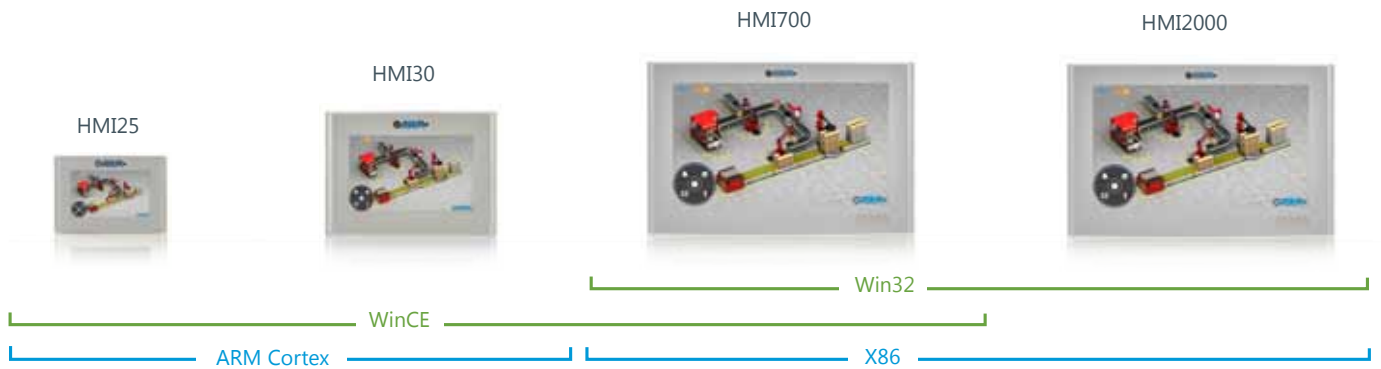

HMI Solutions include a wide range of families based on ARM Cortex and X86 architectures.

- **HMI25**
(ARM Cortex A8, 1 GHz)
- **HMI30**
(ARM Cortex A8, 1 GHz)
- **HMI 700**
(Intel® ATOM E640/E680 1,00/1,60 GHz)
- **HMI2000**
(Intel® ATOM D2550 Dual Core 1,86 GHz)

X86 based solutions have expansion slots that allow the integration of ASEM industrial networking cards supporting a wide range of fieldbuses.



X86
Win 32

ARM Cortex
Win CE

HMI25



HMI25 are the entry level operator panels of the ASEM portfolio. With competitive price HMI25 provides an incomparable number of functionalities with the advanced features of PHMI4 visualization software, in Basic or Advanced version, and the remote assistance software platform ASEM UBIQUITY. They are available with 16 million colors TFT LED backlight LCD displays in 4.3" and 7" sizes with 16:9 aspect ratio, with Aluminum or Aluminum True Flat front panels. HMI25 are based on an ARM Cortex A8 processor, 1 GHz (Freescale i.MX535) and Windows Embedded Compact 7 Pro operating system.

The motherboard includes the ASEM Smart Memory System, with 1 GB system RAM (DDR3-800), a write-protected 256 MB Nand-Flash for the operating system and Runtime storage, 4 GB eMMC memory for storage and management of HMI project data, an RS-232/422/485 configurable serial port with MPI support, a USB 2.0 interface and a 100 Mbps Ethernet interface. HMI25 includes the ASEM System Manager, a series of software utilities to improve the operator panels management.



+ Highlights

- Ubiquity Remote Assistance Software with remote access to the system and to Ethernet and Serial sub-networks
- ARM Cortex A8 Processor at 1 GHz
- ASEM Smart memory system
- 4.3" and 7" displays in 16:9 aspect ratio
- Front panel in Aluminium or Aluminum True Flat
- IP66K front degree of protection - Enclosure type 4X (Indoor use only)
- Operating temperature 0°C ÷ +50°C
- UL 508 listed component

PREMIUM HMI 4

UBIQUITY

UL US LISTED

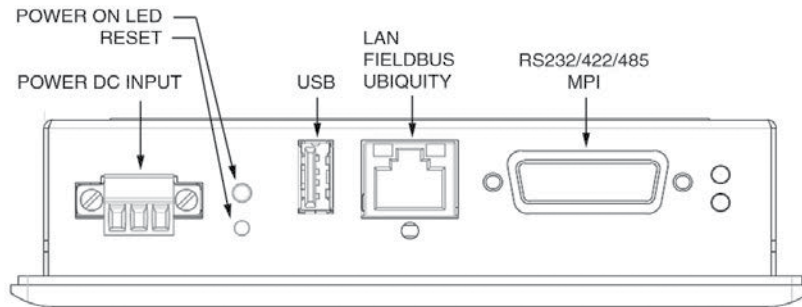

ETHERNET

→ 1 x 100 Mbps with industrial IEEE1588 communication protocol support and for Internet connection and connection to Ubiquity services

SERIAL

1 x RS232/422/485 (DB15 male)
 → MPI compatibility up to 187Kb/s
 → Programmable

POWER SUPPLY

Industrial connector
 → Input voltage 18÷36 VDC
 → Overvoltage protection
 → Polarity inversion protection

USB

1 x USB 2.0 Type-A (rear)
 → Max 500mA
 → Software switch-off

	HMI25 / HMI25-TF
HMI Software	PREMIUM HMI 4 BASIC ADVANCED
REMOTE ASSISTANCE SW	ASEM UBIQUITY PRO
O.S. CERTIFIED	Windows Embedded Compact 7 Pro
PROCESSOR	ARM Cortex A8 1GHz
DRAM / SYSTEM MEMORY	1 GB
MASS STORAGE	256 MB NAND-FLASH 4 GB eMMC (SSD)
LED backlight TFT LCD	4,3" W - 480x272 7" - 800x480
TOUCHSCREEN	Resistive 4 wires
FRONT PANEL	Aluminum / Aluminum True Flat
PROTECTION DEGREE	IP66 front panel
INTERFACES	1 x LAN 100Mbps 1 x USB 2.0 (Type-A, rear) 1 x SERIAL with MPI support (187Kb/s)
POWER SUPPLY UNIT	24VDC input voltage
OPERATING TEMPERATURE	0° - 50°C
APPROVALS	CE, cULus LISTED (508)

HMI30



HMI30 operating panels integrate the numerous and advanced features of Premium HMI visualization software, in Basic or Advanced version, and the remote assistance software platform Ubiquity. The HMI30 operator panel family provides a wide range of sizes with 16 million colors LED backlight TFT LCDs, and Aluminum and Aluminum TrueFlat front panels. ASEM HMI30 features a 1 GHz ARM Cortex A8 processor (Freescale i.MX535) with Windows Embedded Compact 7 Pro operating system. The motherboard features 1 GB system RAM (DDR3-800), a writeprotected 256 MB Nand-Flash for the operating system and Runtimes storage,

4 GB eMMC memory for storage and management of HMI project data and a slot for a removable SDHC memory card. The motherboard has a RS-232/422/485 configurable serial port with MPI support, two USB 2.0 interfaces, one Ethernet interface 10/100 Mbps and one Ethernet interface 100 Mbps. The HMI30 is equipped with a 24VDC power supply with an optional power backup for micro-interruption with supercapacitors. HMI30 includes the ASEM System Manager, a series of software utilities to improve the operator panels management.



+ Highlights

- Ubiquity Remote Assistance Software with remote access to the system and to Ethernet and Serial sub-networks
- ARM Cortex A8 Processor at 1 GHz
- ASEM Smart memory system
- 5.7", 8.4", 10.4", 12.1", 15" displays in 4:3 aspect ratio and 7" and 15.6" displays in 16:9 aspect ratio
- Front panel in Aluminum or Aluminum True Flat
- IP66K front degree of protection - Enclosure type 4X (Indoor use only)
- Operating temperature 0°C ÷ +50°C
- UL 508 listed component

PREMIUM HMI 4

UBIQUITY

UL US LISTED

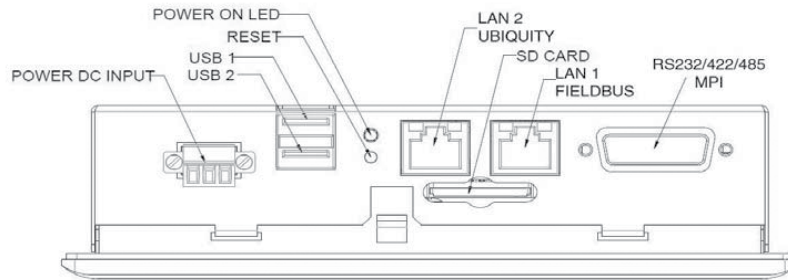

ETHERNET

- 1 x 100 Mbps with support for IEEE1588 industrial communication protocols
- 1 x 10/100 Mbps for Internet connection and connection to Ubiquity services

SERIAL

- 1 x RS232/422/485 (DB15 male)
- MPI compatibility up to 187Kb/s
- Programmable

USB

- 2 x USB 2.0 Type-A (rear)
- Max 500mA
- Software switch-off

POWER SUPPLY

- Industrial connector
- Input voltage 18÷36 VDC
- Overvoltage protection
- Polarity inversion protection
- Optional Micro UPS to manage small power failures

External access

- SD/SDHC Slot (push-push)

	HMI30 / HMI30-TF
HMI Software	PREMIUM HMI 4 BASIC ADVANCED
REMOTE ASSISTANCE SW	ASEM UBIQUITY PRO
O.S. CERTIFIED	Windows Embedded Compact 7 Pro
PROCESSOR	ARM Cortex A8 1GHz
DRAM / SYSTEM MEMORY	1 GB
MASS STORAGE	256 MB NAND-FLASH 4 GB eMMC (SSD) External SD/SDHC
LED backlight TFT LCD	5.7" - 640x480 7" - 800x480 8.4" - 800x600 10.4" - 800x600 12.1" - 800x600 12.1" - 1024x768 15.0" - 1024x768 15.6" - 1366x768
TOUCHSCREEN	Resistive 4 wires
FRONT PANEL	Aluminum / Aluminum True Flat
PROTECTION DEGREE	IP66 front panel
INTERFACES	1 x LAN 100Mbps 1 x LAN 10/100Mbps 2 x USB 2.0 (Type-A, rear) 1 x SERIAL with MPI support (187Kb/s)
POWER SUPPLY UNIT	24VDC input voltage / microUPS
OPERATING TEMPERATURE	0° - 50°C
APPROVALS	CE, cULus LISTED (508)

HMI700



HMI700 visualisation systems are based on the entry level Intel® X86 platform ATOM E640 and E680 with Windows Embedded Compact 7 Pro operating system or Windows Embedded Standard 2009. HMI700 integrates the advanced PHMI4 visualisation software features, in Basic, Pro or Advanced version, and UBIQUITY remote assistance software.

The HMI700 family features a wide range of 16 million colors LED backlight TFT LCD displays in various sizes and aspect ratios, Aluminum and Aluminum True Flat front panels. Displays with 4:3 aspect ratio are available with 6.5", 8.4", 10.4", 12.1" and 15" LCD sizes and displays with 16:9 aspect ratio are available with 7", 15.6" and 18.5" LCD sizes.

The motherboard integrates the ATOM E640 (1 GHz) or the ATOM E680 (1,60 GHz) microprocessor, with 1 GB RAM (DDR2), a Compact Flash, a front-access USB 2.0 interface, two Ethernet 10/100/1000 Mbps interfaces, an RS232 serial port and two PCI mini-slots to install ASEM NETcore® X cards for the support of the most widespread industrial fieldbuses such as Profibus, Profinet*, Ethercat, Ethernet IP* and CANopen. HMI700 systems have a 24 VDC (18÷32 VDC) power supply with galvanic isolation and an optional integrated UPS (Uninterruptible Power Supply).



+ Highlights

- Ubiquity Remote Assistance Software with remote access to the system and to Ethernet and Serial sub-networks
- Intel® Atom™ Tunnel Creek E640/E680 1,00/1,60 GHz Processor
- 6.5", 8.4", 10.4", 12.1", 15" displays in 4:3 aspect ratio and 7", 15.6" and 18.5" displays in 16:9 aspect ratio
- Front panels in Aluminum and Aluminum True Flat
- IP66 front degree of protection
- Compact Flash slot on board with external access
- 2 MiniPCI Slots on board for ASEM NETcore® X cards (for industrial fieldbuses)
- Operating temperature 0°C ÷ +50°C
- Isolated power supply with galvanic isolation
- Optional UPS (Uninterruptible Power Supply) for power failures

PREMIUM HMI 4

UBIQUITY

UL US LISTED

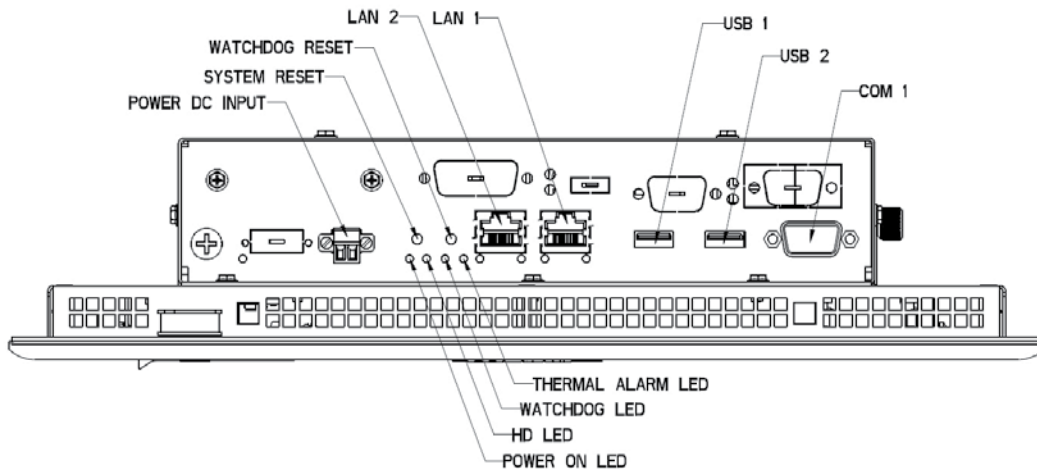

ETHERNET

- 2 x 10/100/1000 Mbps (with Jumbo frames and Wake on LAN features)
- Intel® 82574L Chipset

USB

- 1 x USB 2.0 (front access, IP66 degree of protection)
- 2 x USB 2.0 (rear access)

SERIAL

- 1 x RS232 (DB9 male)
- 1 x RS 232/422/485/MPI (DB15M) optional (also with galvanic isolation)

EXPANSION SLOTS

- 2 x MiniPCI for ASEM NETCore® X cards for fieldbuses

POWER SUPPLY

- Power supply with galvanic isolation
- Industrial connector
- Input voltage 18÷32V DC
- Overvoltage protection
- Polarity inversion protection
- Optional UPS

	HMI700 / HMI700-TF WinCE	HMI700 / HMI700-TF Win32
HMI Software	PREMIUM HMI 4 BASIC ADVANCED	PREMIUM HMI 4 BASIC PRO ADVANCED
REMOTE ASSISTANCE SW	ASEM UBIQUITY PRO	
O.S. CERTIFIED	Windows Embedded Compact 7 Pro	Microsoft Windows Embedded Standard 2009
PROCESSOR	Intel® Atom™ E640 1,00GHz	Intel® Atom™ E680 1,60GHz
CHIPSET	Intel® EG20T1 GB	
VIDEO CONTROLLER	Integrated in Intel® Atom™ microprocessor, 320MHz, LVDS 8bit/color digital interface	Integrated in Intel® Atom™ microprocessor, 400 MHz, LVDS 8bit/color digital interface
DRAM / SYSTEM MEMORY	1 GB	1 GB
MASS STORAGE	1GB / 2 GB / 4 GB Compact Flash	16 GB SSD SATA II MLC (for systems with 8.4") 16 GB SSD Half-Slim SATA II MLC (for systems with 6.5" and 7" LCD)
LED backlight TFT LCD	6.5" - 640x480	6.5" - 640x480
	7" - 800x480	7" - 800x480
	8.4" - 800x600	8.4" - 800x600
	10.4" - 800x600	
	12.1" - 800x600	
	12.1" - 1024x768	
	15.0" - 1024x768	
15.6" - 1366x768		
18.5" - 1366x768		
TOUCHSCREEN	Resistive 5 wires	
FRONT PANEL	Aluminum / Aluminum True Flat	
PROTECTION DEGREE	IP66 front panel	
INTERFACES	2 x LAN 10/100/1000Mbps (RJ45, 1 x Intel® 82574L, 1 x integrated in Intel® EG20T + PHY Realtek® RTL8211E)	
	2 x USB 2.0 (Type-A, rear)	
	1 x USB 2.0 (Type-A, front)	
	1 x RS232 (DB9M)	
ADD-ON INTERFACES	1 x RS232/422/485 (DB15M) + 1 x USB 2.0	
	1 x RS232/422/485 (DB15M) optoisolated + 1 x USB 2.0	
FIELDBUS	NETCore X cards MPI, PROFIBUS Slave, CANopen Master/Slave	
POWER SUPPLY UNIT	24VDC input voltage / microUPS	
OPERATING TEMPERATURE	0° - 50°C	
APPROVALS	CE, cULus LISTED (508)	

HMI2000



ASEM HMI2000 are powered by the 3rd generation 1,86GHz Intel® ATOM D2550 Dual Core processor and feature Microsoft Windows Embedded Standard 7E, 7P, 2009 Operating System. The HMI2000 family integrate Premium HMI visualization software available in Win32 Basic, Pro or Advanced versions, each of which is characterized by greater openness and functionality compared to WinCE versions. HMI2000 are also equipped with the remote assistance software Ubiquity. HMI2000 operator panels feature a wide range of 16 million colours TFT Led Backlight LCDs in various Display sizes.

The front panels are available in aluminium or aluminium True Flat with 5 wires resistive touchscreen. The all-in-one motherboard includes four rear-access USB 2.0 ports, one USB 2.0 port on the front panel, two 10/100/1000 Mbps Ethernet ports with Jumbo Frame e Wake on Lan support, one RS232 serial interface, one CFAST SATA II rear access slot and 2 GB system RAM memory with DDR3 1066 MHz. HMI2000 can be equipped with ASEM NETcore® X boards to communicate with industrial fieldbus as Profibus, MPI and CANopen. The 24VDC HMI2000 (18÷32 VDC) operator panels feature the optional integrated UPS.



+ Highlights

- Premium HMI 4 Win 32 Basic, Pro e Advanced Runtimes
- 1,86 GHz Intel® ATOM D2550 Dual Core processor
- 4:3 format (10,4", 12,1", 15" display size), 5:4 format (17", 19") and 16:9 widescreen (15,6", 18,5", 21,5")
- Front panels in Aluminium and Stainless steel True Flat
- IP66 front degree of protection
- 16/32 GB 2.5" SSD SATA III MLC
- CFAST on board with external access
- Optional ASEM NETcore® X cards (for industrial fieldbuses)
- Operating temperature 0°C ÷ +50°C
- Optional UPS (Uninterruptible Power Supply)

PREMIUM HMI 4

UBIQUITY

UL US LISTED

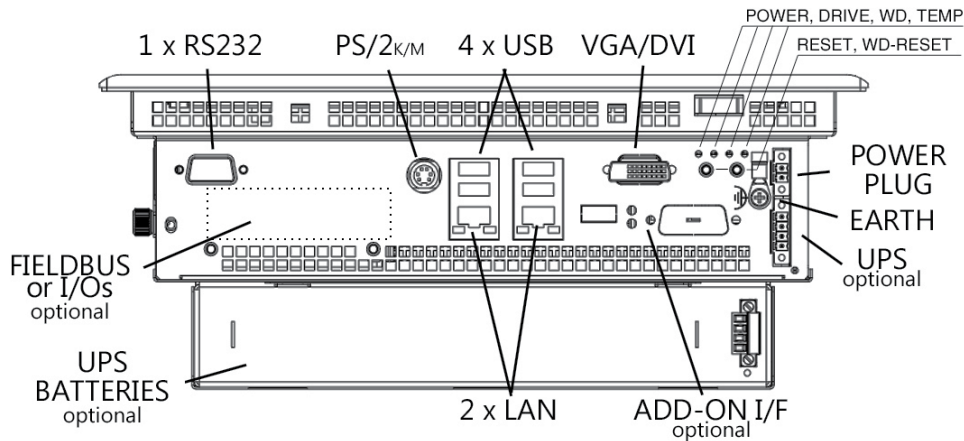

ETHERNET

- 2 x 10/100/1000 Mbps (with Jumbo frames and Wake on LAN features)
- 2 x Intel® 82574L Chipset

USB

- 1 x USB 2.0 (front access, IP66 degree of protection)
- 4 x USB 2.0 (rear access)
- 1 x USB 2.0 (rear access, optional)

SERIAL

- 1 x RS232 (DB9 male)
- 1 x RS 232/422/485 (DB15M) optional (also with galvanic isolation)

INDUSTRIAL FIELDBUS

- ASEM NETcore® X cards for fieldbuses

POWER SUPPLY

- Power supply with galvanic isolation
- Industrial connector
- Input voltage 18÷32V DC
- Overvoltage protection
- Polarity inversion protection
- Optional UPS

	HMI2000 / HMI2000-TF Win32
HMI Software	PREMIUM HMI 4 BASIC PRO ADVANCED
REMOTE ASSISTANCE SW	ASEM UBIQUITY PRO
O.S. CERTIFIED	Microsoft Windows Embedded Standard 7E Microsoft Windows Embedded Standard 7P Microsoft Windows Embedded Standard 2009
PROCESSOR	Intel® Atom™ D2550 1,86GHz
CHIPSET	Intel® NM10
VIDEO CONTROLLER	Integrated in Intel® Atom™ microprocessor, 640MHz, LVDS 8bit/color digital interface
DRAM / SYSTEM MEMORY	2 GB
MASS STORAGE	16 GB / 32 GB SSD 2,5" SATA II MLC
LED backlight TFT LCD	10.4" - 800x600 12.1" - 800x600 12.1" - 1024x768 15.0" - 1024x768 15.6" - 1366x768 17" - 1280x1024 18.5" - 1366x768 19" - 1280x1024 21.5" - 1920x1080
TOUCHSCREEN	Resistive 5 wires
FRONT PANEL	Aluminum / Aluminum True Flat
PROTECTION DEGREE	IP66 front panel
INTERFACES	2 x LAN 10/100/1000Mbps (2 x Intel® 82574L) 4 x USB 2.0 (rear) 1 x USB 2.0 (front) 1 x RS232 (DB9M)
VIDEO OUTPUT	1 x DVI-I
ADD-ON INTERFACES	1 x RS232/422/485 (DB15M)+ 1 x USB 2.0 1 x RS232/422/485 (DB15M) optoisolated + 1 x USB 2.0
FIELDBUS	NETcore X cards MPI, PROFIBUS Slave, CANopen Master/Slave
POWER SUPPLY UNIT	24VDC isolated I UPS
OPERATING TEMPERATURE	0° - 50°C
APPROVALS	CE, cULus LISTED (508)

PAC Solutions Overview

PAC - Programmable Automation Controller

The new frontier of control systems

Industrial automation is moving away from embedded controls, programmable controllers and industrial computers towards a new architecture called PAC, Programmable Automation Controller.

The term **PAC - Programmable Automation Controller** - indicates compact or hybrid modular controllers that combine the features and capabilities of a control system based on PC architecture with those of a typical PLC - programmable logic controller. The basic difference between a PAC and a PLC is the **software component**, which provides an intuitive graphic programming language, similar to a flow chart, but linked to **real-time operating systems** and with the possibility to program reconfigurable hardware. The control programs are generally developed with generic software tools that allow to design the program so that it can be shared with several computers, processors, HMI terminals or other components of the control system architecture. PACs are especially suited for communications that leverage standard protocols and network interfaces. They are usually enclosed in chassis no bigger than that of a common PLC.

This space has room for an advanced microprocessor, several storage modules (both volatile and permanent), axis control modules and different types of communication interfaces. The on-board intelligence is supplied with the tools of a typical real-time operating system, capable of offering reduced latency times and a determinism suitable to fulfil critical tasks, and with an advanced application software usually implemented on PC development platforms and then "downloaded" to the device.

In a competitive context where machine manufacturers are compelled to renew their automation solutions by integrating **standard, open and flexible technological structures** that quickly respond to the growing demands of customization, delivery time reduction and lower costs, it becomes suitable that producers can consider and evaluate the possibility to develop control functions with PAC systems, with **enhanced scalability in calculation**

power, wide availability of communication interfaces for industrial networking, data storage and archiving functions, making use of several storage modules (both volatile and permanent).

The most advanced PACs support also graphic video interfaces, optimising automation costs by integrating control and visualization activities into a single system. PACs with high-performance processors further optimize automation costs by integrating Motion Logic (Soft-Motion) and Control Logic (Soft- PLC) into one integrated PLC-CNC control system.

ASEM PAC Solutions

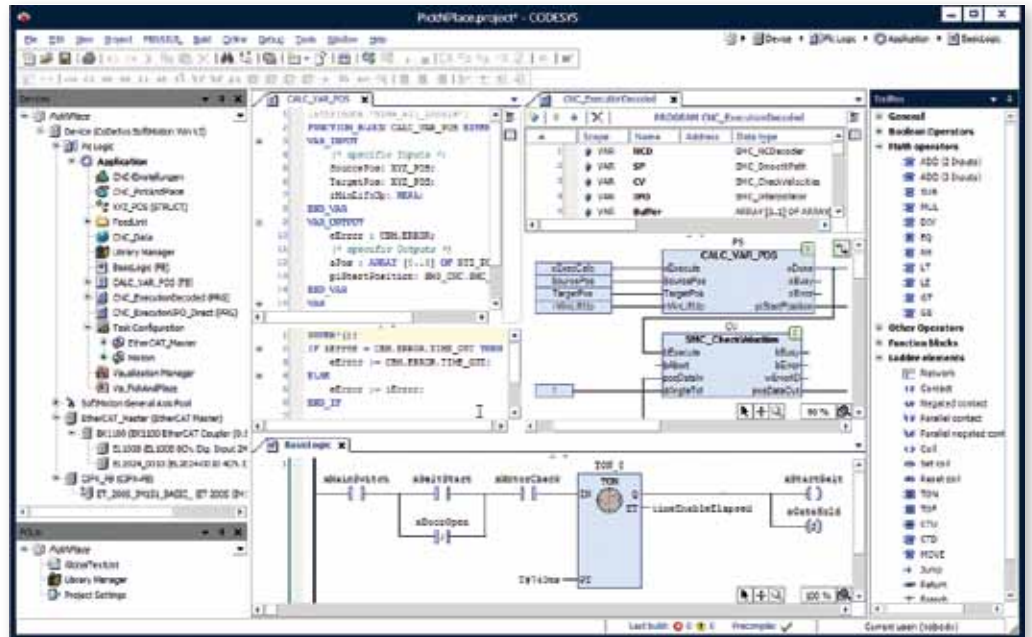

ASEM logic controllers base their PLC functionalities on the consolidated and widespread CODESYS SoftPLC of the German 3S, with a highly efficient implementation of version 3.5 which guarantees the deterministic execution of PLC control logic with WIN CE and WIN 32/64 operating systems. It transfers projects between various operating systems and hardware platforms without the need to change the project code. Like all traditional PLCs, CODESYS platform also has a development environment, CODESYS Engineering, to realise projects which are

then executed by the runtime. CODESYS provides availability of the most used industrial fieldbuses in master mode (such as CANopen, Profibus, Profinet, Ethernet IP, EtherCAT, Modbus RTU and Modbus TCP) to communicate with field devices.

CODESYS - The number 1 control tool in the world

With over a million installations, CODESYS by 3S-Smart Software Solutions has become a global standard in Industrial Automation, being the number one platform (excluding Multinational PLC manufacturers) in the world.



CODESYS

CODESYS Highlights



Flexible PLC and Motion logic control in a single development tool

- Perfect integration of auxiliary components for automation engineering:
 - SoftPLC
 - SoftMotion
 - CNC
- CODESYS SoftMotion covers all motion functions, from motion management of single axis to 3D CNC interpolations
- The possibilities offered by the standard IEC 61131-3 give no limits to the complexity of the tasks to be assigned

Transferability of projects to different platforms

- A project can be used on different platforms and operating systems without the need to modify or change settings in the development tool

5 different programming languages in one flexible development tool

- **Text editor:**
 - **IL** (Instructions List) similar to the Assembler programming language
 - **ST** (Structured Text) similar to programming in PASCAL or C
- **Graphic editors:**
 - **LD** (Ladder) allows the programmer to virtually combine relay contacts and coils
 - **FBD** (Function Block Diagram) allows the user to quickly program both Boolean and analogue expressions
 - **SFC** (Sequential Function Chart) suitable to program sequential processes

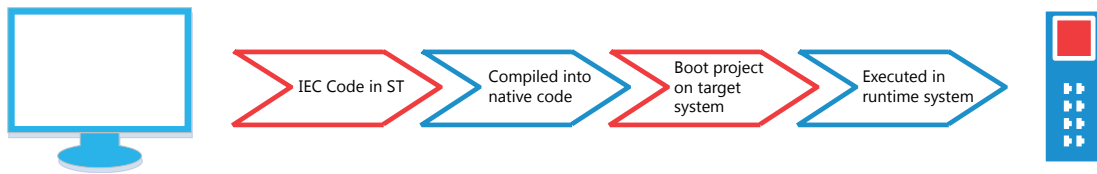

Performance guaranteed with the proprietary compiler integrated in the development tool

→ Proprietary compilers integrated in the development environment transform the code created by CODESYS into native code for machinery (binary code) then downloaded on the controller

- The compiler does not weigh on the machinery hardware, lightening the load and therefore optimising controller performances
- Performance is much improved compared to controllers executing an interpreted code

High potential and usability for the effective implementation of complex automation projects

→ Fast machine code for different devices and complex applications, generated by compilers widely tested in industrial environments

→ Scalable function - usable both on simple configurators and potent auxiliary tools for the static analysis of the code or integrated UML diagrams

→ Modular programming philosophy orientated to the repeated use of functional blocks in the libraries

Several debugging functions help in writing and maintaining applications

- Breakpoint
- Force
- Trace
- Debugging
- Online change
- Multi application
- Recipe
- Symbol management
- Multi-user operation

> CODESYS integrated property compiler functioning



CODESYS

The components

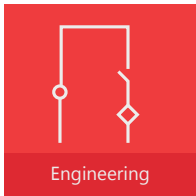
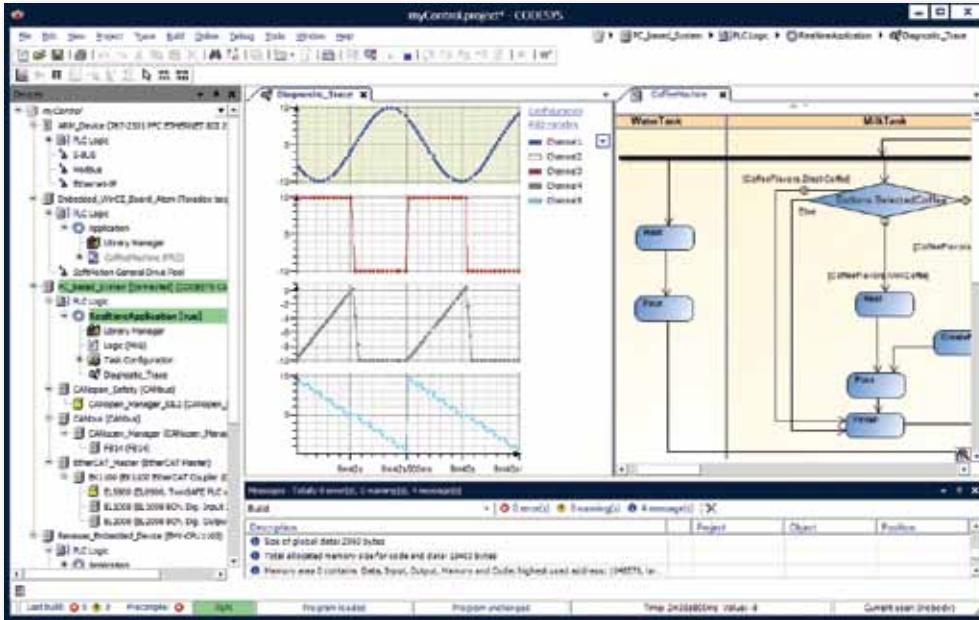

CODESYS advanced development tool - includes different programming languages for the development of applications in a single expandable platform

→ Modern development platform with editor and debugger compliant with **IEC 61131-3** standards.

→ Integrated compilers transform the code created by CODESYS into **native code** for machinery (binary code) then downloaded on the controller, thus enhancing performance of the system for industrial applications. Several ASEM CPUs are supported, from

ARM Cortex A8 platforms to different X86 processors.

→ Once online, CODESYS offers debugging features such as monitoring/writing/forcing of variables by setting single passages of breakpoints/performing or recording variable values online in the controller in a ring buffer (Sampling Trace)

→ Availability of additional tools for easier high-level programming language.

→ . Modular expandability with specific plug-ins.

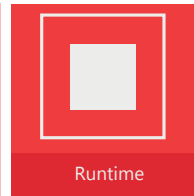

The installation of CODESYS Control Runtime System converts any type of industrial PC into a powerful scalable PLC leveraging the performance of the PC itself. Several ASEM systems can be programmed with the CODESYS development tool, becoming real controllers based on ARM Cortex or X86 processors.

→ ASEM offers controllers based on Windows 32/64 or Windows CE operating systems

→ ASEM integrates the CODESYS Control Runtime on three PAC systems (Programmable Automation Controller) dedicated to control:

- LP30/31 (ARM based)
- LP700 (ATOM based)
- LP2000 (ATOM based)

→ The CODESYS Control Runtime System can also be installed on all other X86 families of the ASEM Industrial PC range, able to support also SoftMotion + CNC applications

CODESYS

The components

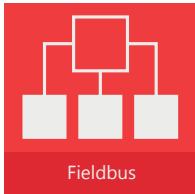

CODESYS - Fieldbus

The CODESYS development environment integrates the support of different fieldbuses such as CANopen, Profibus, EtherCAT or Ethernet IP, including additional protocol stacks

- Support for the most used fieldbuses with integrated configurator: CANopen, Modbus, Profibus, etc.
- Support for real-time Ethernet systems: EtherCAT, EtherNET/IP, etc.
- Management of I/O assignment and diagnosis independent from fieldbuses



CODESYS Motion+CNC

Logic control and Motion control in one development tool. An optional modular solution is completely integrated in the CODESYS programming system to manage complex movements with a IEC 61131-3 programmed controller

- Management of any type of application, from simple basic Motion applications to complex CNC controls
- Library modules for the control of interpolations and transformations and for axis control - PLCopen



PAC Solutions Overview

ASEM PAC Solutions



The current portfolio of ASEM PAC solutions includes the LP30/31 family with ARM Cortex A8 (Freescale i.MX535 1GHz or or i.MX537 800 MHz) processors and Windows Embedded Compact 7 Pro operating system, the LP700 family based on Intel® ATOM E640 1 GHz or E680 1,6 GHz processors and Windows Embedded Compact 7 and WES7. The LP2000 family is based on Intel® Atom™ D2550 Dual Core (1,86 GHz) processor and Windows Embedded Standard 7 or Windows Embedded Compact 7 Pro Operating Systems.

LP30/31, LP700 and LP2000 are the only Panel Programmable Automation Controllers (Panel PAC) on the market that combine control, visualization, and remote assistance functions.

In addition to the PLC logic, ASEM PAC systems provide simultaneous execution of Premium HMI visualisation software and UBIQUITY remote assistance software platform, representing the new frontier of "Ready to Automation" systems.

Aside from being used in PAC solutions, CODESYS SoftPLC Runtime can also be installed as an option on the entire ASEM Industrial PCs range.

Soft-Motion and CNC logic can also be installed on ASEM systems, both with Windows CE and Windows 32/64 operating systems.

For further information regarding the potential of CODESYS control software on ASEM Industrial PCs, visit our website: <http://www.asem.it/prodotti/industrial-automation/control-software/>

LP30/31



LP30/31 systems are the only ARM-based Panel PACs - Programmable Automation Controllers - on the market combining visualisation, control and remote assistance functions. On Windows Embedded Compact 7 Pro, they integrate the numerous and advanced features of PHMI4 visualization software, in Basic or Advanced versions, CODESYS SoftPLC 3.5 and ASEM UBIQUITY. LP30/31 Panel PAC family is characterised by a wide range of 16 million colors LED backlight TFT LCD sizes with Aluminum or Aluminum True Flat front panels. Available with 5.7", 8.4", 10.4", 12.1" and 15" LCD sizes in 4:3 aspect ratio and with 7" and 15,6" LCD sizes in 16:9 aspect ratio.

LP30/31 systems are based on a motherboard with an ARM Cortex A8 1 GHz/800 MHz processor (Freescale i.MX535 or Freescale i.MX537) and the ASEM Smart Memory System, with 512 MB system Ram (DDR3-800), 256 MB Nand-Flash, write-protected, for the operating system and Runtime of PHMI4 and CODESYS SoftPLC, a 2 GB eMMC memory for management and storage of HMI project data and a slot for a removable SDHC memory card. The motherboard has also an RS-232/422/485 configurable serial port with MPI support, two USB 2.0 interfaces and two Ethernet interfaces 10/100 and 100 Mbps. LP31 has also a CAN interface.



+ Highlights

- CODESYS SoftPLC for control applications with retentive data management via MicroUPS
- EtherCAT, Modbus TCP/IP, Modbus RTU and CANopen fieldbuses
- Premium HMI 4 visualisation software
- Ubiquity remote assistance software with remote access to the system and to the Ethernet and Serial sub-networks
- ARM Cortex A8 (1 GHz processor - LP30, 800 MHz processor - LP31)
- ASEM Smart memory system
- 5.7", 8.4", 10.4", 12.1", 15" displays in 4:3 aspect ratio and 7" and 15,6" displays in 16:9 aspect ratio
- Front panel in Aluminum or Aluminum True Flat
- IP66K Front degree of protection - Enclosure type 4X (Indoor use only)
- Operating temperature 0°C ÷ +50°C
- UL 508 listed component



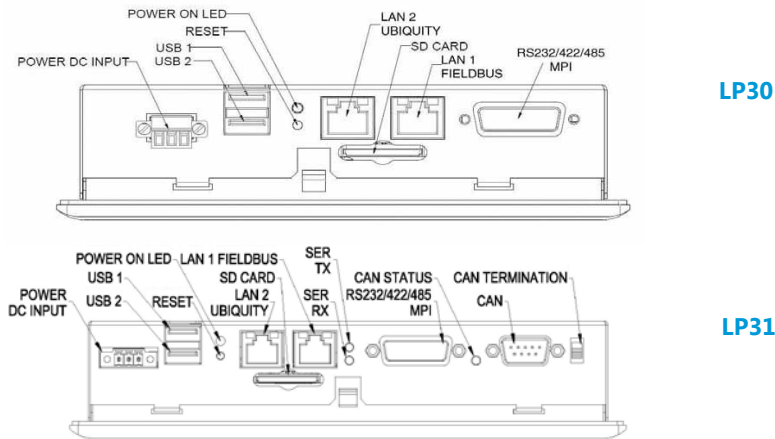

ETHERNET

- 1 x 100 Mbps with support for IEEE1588 industrial communication protocols
- 1 x 10/100 Mbps for connection to the Internet and to Ubiquity services

CAN (LP31)

- 1 x CAN (DB9 male)

SERIAL

- 1 x RS232/422/485 (DB15 male)
- Programmable

USB

- 2 x USB 2.0 Type-A (rear)
- Max 500mA
- Software Switch-off

EXPANSION SLOTS

- SD/SDHC Slot (push-push)

POWER SUPPLY

- Industrial connector
- Input voltage 18÷36 VDC
- Overvoltage protection
- Polarity inversion protection
- Micro UPS to manage retentive variables and micro-interruptions of the power supply
- Galvanic isolation of the power supply (only LP31)

	LP30	LP30-TF	LP31	LP31-TF
CONTROL SOFTWARE	CODESYS SP v3.x			
supported protocols	EtherCAT Master, MODBUS TCP Master, MODBUS RTU Master		EtherCAT Master, MODBUS TCP Master, MODBUS RTU Master, CANopen Master	
HMI Software	PREMIUM HMI 4 BASIC ADVANCED			
REMOTE ASSISTANCE SW	ASEM UBIQUITY PRO			
OS INSTALLED	Microsoft Windows Embedded Compact 7 Pro			
LED backlight TFT LCD	5.7" - 640x480		7" - 800x480	
	7" - 800x480		8.4" - 800x600	
	8.4" - 800x600		10.4" - 800x600	
	10.4" - 800x600		12.1" - 800x600 / 1024x768	
	12.1" - 800x600 / 1024x768		15.0" - 1024x768	
	15.0" - 1024x768		15.6" - 1366x768	
TOUCHSCREEN	Resistive 4 wires for 5.7" and 7"			
	Resistive 5 wires for other sizes			
FRONT PANEL	Aluminum	True Flat Aluminum	Aluminum	True Flat Aluminum
PROTECTION GRADE	IP66, Enclosure type 4x - frontal			
PROCESSOR	ARM Cortex A8 processor Freescale® i.MX535 1 GHz		ARM Cortex A8 processor Freescale® i.MX537 800 MHz	
SYSTEM MEMORY - RAM	1 GB			
MASS STORAGE	256 MB Read-Only NAND-Flash for operating system and runtime			
	4 GB eMMC (Solid State Disk) 8bit, file system organization for projects and applications			
LAN	1 x Slot SD/SDHC v2.0			
	LAN1 Ethernet 100 Mbps (RJ45)			
	LAN2 Ethernet 10/100 Mbps (RJ45)			
USB	2 x USB 2.0 (Type A, rear)			
SERIAL	1 x RS-232/422/485 (DB15M)			
FIELDBUS INTERFACES	-		1 x CAN optoisolated channel (DB9M) with FlexCAN integrated controller	
POWER SUPPLY UNIT	24VDC		24VDC isolated	
	Backup for microinterruption, max 500ms, with supercapacitors			
OPERATING TEMPERATURE	0° - 50°C			
APPROVALS	CE, cULus			

LP700



LP700 systems are the only ATOM-based Panel PACs - Programmable Automation Controllers - on the market combining visualization, control and remote assistance functions. Based on Windows Embedded Compact 7 Pro or Windows Embedded Standard 7, they integrate CODESYS SoftPLC 3.5, the advanced features of PHMI4 visualization software, in Basic, Pro or Advanced versions, and ASEM UBIQUITY. LP700 Panel PAC family features a wide range of 16 million colors LED backlight TFT LCD sizes with Aluminum or Aluminum True Flat front panels and is available with 6.5" and 8.4" LCD sizes in 4:3 aspect ratio and with 7" sizes in 16:9 aspect ratio.

The motherboard integrates an ATOM E640 (1GHz) or an ATOM E680 (1,6 GHz) microprocessor, with 1 or 2 GB RAM (DDR2), a Compact Flash slot, a front-access USB 2.0 interface, two Ethernet 10/100/1000 Mbps interfaces, an RS232 serial port and two mini-PCI slots to install ASEM NETcore® X cards for the support of the most widespread industrial fieldbuses and the 512 KB NV RAM card that allows to save retentive data in case of power supply interruptions. LP700 systems have a 24 VDC (18÷32 VDC) power supply with galvanic isolation and an optional integrated UPS (Uninterruptible Power Supply).



+ Highlights

- CODESYS SoftPLC for control applications with retentive data management via NV RAM card
- EtherCAT, Modbus TCP/IP, Modbus RTU, CANopen, Profibus, Profinet* and Ethernet IP* fieldbuses
- Premium HMI 4 visualisation software
- Ubiquity remote assistance software with remote access to the system and to the Ethernet and Serial sub-networks
- Intel® Atom™ Tunnel Creek E640/E680 1,00/1,60 GHz Processor
- 6.5", 8.4", 10.4", 12.1", 15" displays in 4:3 aspect ratio and 7", 15.6" and 18.5" displays in 16:9 aspect ratio
- Front panel in Aluminum or Aluminum True Flat
- IP66 Front degree of protection - Enclosure type 4X (Indoor use only)
- Operating temperature 0°C ÷ +50°C
- Isolated power supply with galvanic isolation
- Optional UPS (Uninterruptible Power Supply) for power failures
- UL 508 listed component



The LP700 PAC family, by means of CODESYS SoftPLC, can manage EtherCAT, Modbus TCP/IP and Modbus RTU (serial). Together with ASEM NETcore® X cards LP700 support also CANopen, Profibus, Profinet* and Ethernet IP* master fieldbuses to control automation I/Os and devices. LP700 systems are the PC-based cost-effective solution to meet automation requirements previously managed exclusively by classical PLC + Operator Panel architecture.

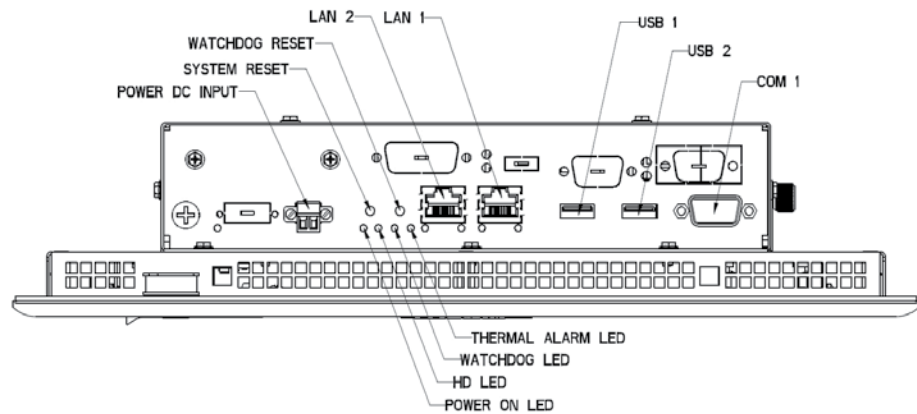

ETHERNET

- 2 x 10/100/1000 Mbps (with Jumbo frames and Wake on LAN features)
- Intel® 82574L Chipset

USB

- 1 x USB 2.0 (front access, IP66 degree of protection)
- 2 x USB 2.0 (rear access)

SERIAL

- 1 x RS232 (DB9 male)
- 1 x RS 232/422/485 (DB15M) optional (also with galvanic isolation)

EXPANSION SLOT

- 2 x MiniPCI for ASEM NETcore® X and NV RAM cards

POWER SUPPLY

- Power supply with galvanic isolation
- Industrial connector
- Input voltage 18÷32V DC
- Overvoltage protection
- Polarity inversion protection
- Optional UPS

	LP700 WinCE	LP700-TF WinCE	LP700 Win32	LP700-TF Win32
CONTROL SOFTWARE	CODESYS SP v3.x		CODESYS SP RTE v3.x	
supported protocols	EtherCAT Master, MODBUS TCP Master, MODBUS RTU Master, PROFIBUS Master, CANopen Master		EtherCAT Master, MODBUS TCP Master, MODBUS RTU Master, PROFIBUS Master, CANopen Master, Profinet IO Controller*, EtherNet/IP Scanner*	
HMI Software	PREMIUM HMI 4 BASIC ADVANCED		PREMIUM HMI 4 BASIC PRO ADVANCED	
REMOTE ASSISTANCE SW	ASEM UBIQUITY PRO			
OS INSTALLED	Microsoft Windows Embedded Compact 7 Pro		Microsoft Windows Embedded Standard 7E Microsoft Windows Embedded Standard 7P	
LED backlight TFT LCD	6.5" - 640x480 7" - 800x480 8.4" - 800x600			
TOUCHSCREEN	Resistive 5 wires GFG (Optional)	Resistive 5 wires	Resistive 5 wires GFG (Optional)	Resistive 5 wires
FRONT PANEL	Aluminum	Aluminum True Flat	Aluminum	Aluminum True Flat
PROTECTION GRADE	IP66 - frontal			
PROCESSOR	Intel® Atom™ E640 1,00GHz Intel® Atom™ E680 1,60GHz		Intel® Atom™ E680 1,60GHz	
CHIPSET	Intel® EG20T			
VIDEO CONTROLLER	Integrated in Intel® Atom™ microprocessor, 320/400 MHz, LVDS 8bit/color digital interface		Integrated in Intel® Atom™ microprocessor, 400 MHz, LVDS 8bit/color digital interface	
SYSTEM MEMORY - RAM	1 GB		2 GB	
MASS STORAGE	16 GB SSD Half-Slim SATA II MLC (for systems with 6.5" and 7" LCD) 16 GB SSD SATA II MLC (for systems with 8.4" or greater LCD)		16/32 GB SSD SATA II MLC (for systems with 8.4") 16/32 GB SSD Half-Slim SATA II MLC (for systems with 6.5" and 7" LCD)	
LAN	2 x LAN 10/100/1000Mbps (RJ45, 1 x Intel® 82574L, 1 x integrated in Intel® EG20T + PHY Realtek® RTL8211E)			
USB	2 x USB 2.0 (Type-A, rear) 1 x USB 2.0 (Type-A, front)			
SERIAL	1 x RS232 (DB9M)			
ADD-ON INTERFACES	1 x RS232/422/485 (DB15M) + 1 x USB 2.0			
(optional, max 1)	1 x RS232/422/485 (DB15M) optoisolated + 1 x USB 2.0			
FIELD BUS INTERFACES (optional)	NETcore X cards for MPI, PROFIBUS Master, CANopen Master		NETcore X cards MPI, PROFIBUS Master, CANopen Master, Profinet IO Controller, EtherNet/IP Scanner	
RETENTIVE MEMORY (optional)	512KB NVRAM			
POWER SUPPLY UNIT	24VDC isolated		24VDC isolated UPS (optional)	
OPERATING TEMPERATURE	0° - 50°C			
APPROVALS	CE, cULus LISTED (508)			

* on demand

LP2000



The LP2000 family based on Windows Embedded Standard 7 or Windows Embedded Compact 7 Pro O.S., integrates the SoftPLC CODESYS 3.5, PHMI4 visualization software and ASEM UBIQUITY. The motherboard is equipped with the 3rd generation Dual Core processor Intel® ATOM D2550 1,86 GHz with 1 GB or 4 GB (DDR3) RAM System memory, 5 USB 2.0 interfaces (1 front access and 4 rear access), 2 Ethernet 10/100/1000 Mbps interfaces and 1 RS232 serial port and two mini-PCI slots to install ASEM NETcore® X cards for the support of the most widespread industrial fieldbuses and the 512 KB NV RAM card that allows to save retentive data in case of power supply interruptions. LP2000 systems have a 24 VDC (18÷32 VDC) power supply with galvanic isolation

and an optional integrated UPS (Uninterruptible Power Supply). The Panel PAC LP2000 has a wide range of 16 million colors TFT LCD LED backlight sizes with aluminum and aluminum True Flat front panel. The LP2000 PAC family, by means of CODESYS SoftPLC, can manage EtherCAT, Modbus TCP/IP and Modbus RTU (serial). Together with ASEM NETcore® X cards LP700 support also CANopen, Profibus, Profinet* and Ethernet IP* master fieldbuses to control automation I/Os and devices. The LP2000 is a PC-based cost-effective and powerful solution that meets the needs of automation previously managed exclusively by the classical architecture PLC + Operating Panel.



+ Highlights

- SoftPLC CODESYS for control applications with retentive data management via NV RAM card
- Supported fieldbuses: EtherCAT, Modbus TCP/IP, Modbus RTU, CANopen, Profibus, Profinet and Ethernet IP
- Premium HMI 4 visualization software
- Ubiquity remote assistance software with remote access to the system and to the Ethernet and Serial sub-networks
- Intel® Atom™ D2550 Dual Core (1,86 GHz)
- Front panel in Aluminum or Aluminum True Flat
- IP66 Front degree of protection - Enclosure type 4X (Indoor use only)
- Operating temperature 0°C ÷ +50°C
- Isolated power supply with galvanic isolation
- Optional UPS (Uninterruptible Power Supply) for power failures
- UL 508 listed component



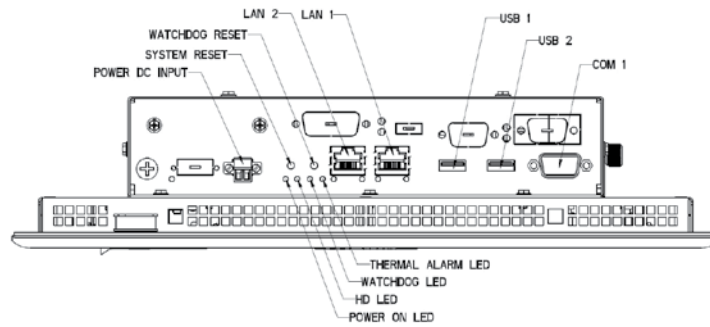

ETHERNET

- 2 x 10/100/1000 Mbps (with Jumbo frames and Wake on LAN features)
- 2 x Intel® 82574L Chipset

USB

- 1 x USB 2.0 (front access, IP66 degree of protection)
- 4 x USB 2.0 (rear access)
- 1 x USB 2.0 (rear access, optional)

SERIAL

- 1 x RS232 (DB9 male)
- 1 x RS232/422/485 (DB15M) optional (also with galvanic isolation)

EXPANSION SLOT

- 2 x MiniPCI for ASEM NETcore® X and NV RAM cards

POWER SUPPLY

- Power supply with galvanic isolation
- Industrial connector
- Input voltage 18÷32V DC
- Overvoltage protection
- Polarity inversion protection
- Optional UPS

	LP2000 WinCE	LP2000-TF WinCE	LP2000 Win32	LP2000-TF Win32
CONTROL SOFTWARE	CODESYS SP v3.x		CODESYS SP RTE v3.x	
supported protocols	EtherCAT Master, MODBUS TCP Master, MODBUS RTU Master, PROFIBUS Master, CANopen Master		EtherCAT Master, MODBUS TCP Master, MODBUS RTU Master, PROFIBUS Master, CANopen Master, Profinet IO Controller*, EtherNet/IP Scanner*	
HMI Software	PREMIUM HMI 4 BASIC ADVANCED		PREMIUM HMI 4 BASIC PRO ADVANCED	
REMOTE ASSISTANCE SW	ASEM UBIQUITY PRO			
OS INSTALLED	Microsoft Windows Embedded Compact 7 Pro		Microsoft Windows Embedded Standard 7E Microsoft Windows Embedded Standard 7P	
LED backlight TFT LCD	10.4" - 800x600 12.1" - 800x600 12.1" - 1024x768 15.0" - 1024x768 15.6" - 1366x768 17" - 1280x1024 18.5" - 1366x768 19" - 1280x1024 21.5" - 1920x1080			
TOUCHSCREEN	Resistive 5 wires GFG (Optional)	Resistive 5 wires	Resistive 5 wires GFG (Optional)	Resistive 5 wires Aluminum True Flat
FRONT PANEL	Aluminum	Aluminum True Flat	Aluminum	Aluminum True Flat
PROTECTION GRADE	IP66 - frontal			
PROCESSOR	Intel® Atom™ D2550 1,86GHz			
CHIPSET	Intel® NM10			
VIDEO CONTROLLER	Integrated in Intel® Atom™ microprocessor, 640MHz, LVDS 8bit/color digital interface			
SYSTEM MEMORY - RAM	1 GB		4 GB	
MASS STORAGE	16 GB / 32 GB SSD 2,5" SATA II MLC			
LAN	2 x LAN 10/100/1000Mbps (2 x Intel® 82574L)			
USB	4 x USB 2.0 (rear) 1 x USB 2.0 (front)			
SERIAL	1 x RS232 (DB9M)			
VIDEO OUTPUT	1 x VGA / 1 x DVI-I			
ADD-ON INTERFACES (optional, max 1)	1 x RS232/422/485 (DB15M)+ 1 x USB 2.0 1 x RS232/422/485 (DB15M) optoisolated + 1 x USB 2.0			
FIELD BUS & I/O	NETcore X cards for MPI, PROFIBUS Master, CANopen Master		NETcore X cards MPI, PROFIBUS Master, CANopen Master, Profinet IO Controller, EtherNet/IP Scanner	
RITENTIVE MEMORY (optional)	512KB NVRAM			
POWER SUPPLY UNIT	24VDC isolated		24VDC isolated UPS (optional)	
OPERATING TEMPERATURE	0° - 50°C			
APPROVALS	CE, cULus LISTED (508)			

* on demand







ASEM S.p.A.

ASEM | Artegna | Headquarters
Via Buia 4
33011 Artegna (UD) | Italia
Phone: +39/0432-9671
Fax: +39/0432-977465

ASEM | Giussano
Via Prealpi 13/A
20833 Giussano (MB) | Italia
Phone: +39/0362-859111
Fax: +39/0362-859121

ASEM | Germany
Walbenstraße 41
72127 Kusterdingen-Wankheim
Phone: +49 (0) 7071 7963 070
Fax: +49 (0) 7071 7963 071

email: industrialautomation@asem.it
website: www.asem.it

USER INFORMATION

Copyright © ASEM 2014. All right reserved ASEM reserves the right to make changes, corrections and improvements to the products and programs described at its sole discretion and at any time, without any obligation to notify users. Nor can be excluded inconsistencies and inaccuracies, despite the continued pursuit of perfection. The content of this document is still subject to periodic review. Pictures, diagrams and examples in this document are for illustrative purposes only. ASEM decline any responsibility or liability for actual use based on the examples, diagrams and technical data therein reported. Premium HMI®, NETcore® are ASEM trademarks. Microsoft, Windows, Windows CE, Windows are registered trademark by Microsoft Corporation. Celeron, Core, Intel, Intel® logo, Intel® Atom, Intel® Core, Pentium are registered trademark by Intel® Corporation. Other companies, products or services mentioned on this publication can be registered trademarks of other companies.